

Regional Headquarters

Europe, Middle East and Africa

UNIQCHEM GmbH

Hollandstrasse 7
D-48527 Nordhorn, Germany
Tel: +49 (0) 5921 853 7428
Email: eu@uniqchem.com

Asia Pacific

UNIQCHEM Shanghai Co., Ltd.

1809 Qixin Road, West Zone, Building 8 Room 2308
Red Dot City ,Minhang District ,
201101 Shanghai , China
Tel: +86 (0) 21 5433 6480
Email: asia@uniqchem.com

www.uniqchem.com

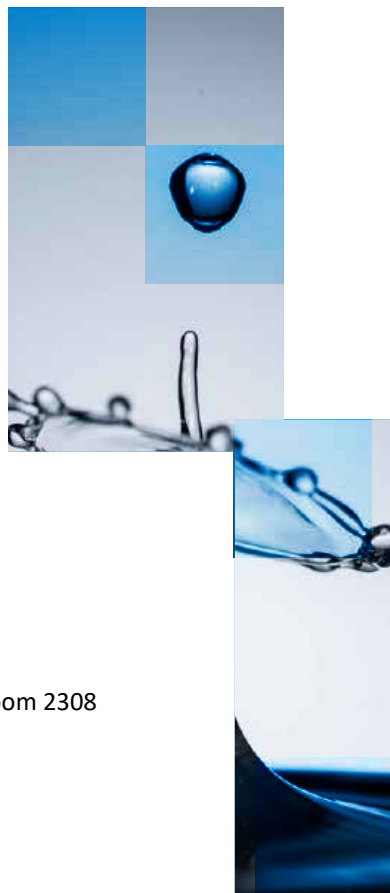

Product Information

Paint additives

Ink and inkjet additives

Composites

PVC Plastisols

Product Brochure Additives

UNIQCHEM



This information and all further technical advice is based on our present knowledge and experience. However, it implies no liability or other legal responsibility on our part, including with regard to existing third party intellectual property rights, especially patent rights. In particular, no warranty, whether express or implied, or guarantee of product properties in the legal sense is intended or implied. We reserve the right to make any changes according to technological progress or further developments. The customer is not released from the obligation to product careful inspection and testing of incoming goods. Performance of the product described herein should be verified by testing, which should be carried out only by qualified experts in the sole responsibility of a customer. Reference to trade names used by other companies is neither a recommendation, nor does it imply that similar products could not be used.

Company Introduction

UNIQCHEM is a privately owned specialty additive company with holding company in the UK founded in 2010.

As the premier leader in manufacturing and development of high-performance additives, the global network of **UNIQCHEM** covers many countries in Europe, America and Asia with regional headquarters in Germany, China and USA.

The regional headquarters consisting of a dedicated team of professionals with decennia of experience in the development, application know-how, production manufacturing, technical service and sales of additives for coatings and inks industry.

Our manufacturing and development of innovative high performance specialty additives are based in Germany and China. Global purchasing of raw materials is taking place from Germany to guarantee the consistency of our products.

Our technology platform contains of many technologies: free radical polymerization, poly-addition reactions, poly-condensation reactions, hydrosilylation and special blending technologies.

From our global technical service lab network, we offering our customers the best solutions of product recommendations. We are committed creating added value and improving our customers' formulations with our complete range of specialty additives offering them the right solution.

UNIQ[®]FOAM for defoamers and air release agents, **UNIQ[®]FLOW** for wetting and leveling agents, **UNIQ[®]SPERSE** and **UNIQ[®]JET** for wetting and dispersing agents, **UNIQ[®]LIGHT** for HALS and light stabilizers and **UNIQ[®]VIS** for specialties have achieved worldwide recognition for their performance, quality and technical innovation.

We continue to bring new technologies and products to the markets and to work collaboratively with our customers to build on our technical expertise.

Special attention is given to our development of new products. To be innovative, our products needs to give an added value to our customers. Therefore, we continuous developing new products with improved features. That our R&D is successful is proven by the sales of new product developed in the last years. New in-house developed technologies have nowadays about 45% contributions to our global sales, what should be further increase in the coming years.

We want to be your solution partner in specialty additives by strengthening your market position through technology and service, therefore our slogan is 'Customized Solutions':

- Customized Solutions to our Customers by finding solutions and sharing technical experiences through our corporation.
- Customized Solutions to our employees by offering them career opportunities and a safe and healthy working environment.
- Customized Solutions for the future and our environment by making use of environmentally friendly raw materials and less or/and non-polluting products serving the new upcoming technologies.

Our goal is to be the fastest growing and most competitive supplier of specialty additives in this market by offering the best service, supply and samples by our communication, corporation and commitment to you.

UNIQ[®]FOAM

UNIQ[®]FLOW

UNIQ[®]SPERSE

UNIQ[®]VIS

UNIQ[®]LIGHT

UNIQ[®]JET



Catalog

Company Introduction	2
THEORY	
Defoaming Technology	4-7
Flow and Leveling Technology	8-13
Dispersing Technology	14-21
Light stabilization technology	22-25
Product range Coatings	
UNIQ[®]FOAM	28-47
UNIQ[®]FLOW	48-69
UNIQ[®]SPERSE	70-93
UNIQ[®]LIGHT	94-99
UNIQ[®]VIS	100-102
Product range Ink and Inkjet	
UNIQ[®]SPERSE	106-112
UNIQ[®]JET	114-123
Product range Plastic, PVC plastisols, SMC/BMC	
UNIQ[®]FOAM	126-133
UNIQ[®]FLOW	135
UNIQ[®]SPERSE	136-153
Overview	154-155

Solvent Product Table



Product line and nomenclature



Additives for the coating industrie:

UNIQ[®]FOAM	100 - 200
UNIQ[®]FLOW	300 - 400
UNIQ[®]SPERSE	500 - 600 - 700
UNIQ[®]VIS	800
UNIQ[®]LIGHT	900

S = Solvent based

W = Water borne

U = Universal

Additives for ink and inkjet:

UNIQ[®]SPERSE	9000
UNIQ[®]JET	9000

Additives for Plastic and composites:

UNIQ[®]FOAM	P-5xx
UNIQ[®]FLOW	P-3xx
UNIQ[®]SPERSE	P-1xxx and P-9xxx

Defoaming technology

In industrial processes, foam can cause serious problems like:

- They cause defects on surface coatings.
- They prevent the efficient filling of containers.

To avoid these issues, the need for a defoamer or air-release agents is necessary. UNIQCHEM offers these additives under the brand **UNIQ® FOAM**.

A defoamer or an anti-foaming agent is a chemical additive that reduces and hinders the formation of foam in industrial process liquids or is added to break a formed foam already. We can make a distinction between macro- and micro-foam. Macro-foam is often formed at the surface of the coating and micro-foam is entrapment of small air bubbles, they are not able to raise fast enough to the surface. For micro foam you need a so-called air release agent to coagulate the micro bubbles to bigger air bubbles so they can raise faster to the surface to be destroyed.

Defoaming

Defoaming

During the production and application of paint systems, foam is an undesired side-effect of mixing, usually slowing production and making it difficult to fill vessels with the correct amount of paint, in addition to causing surface defects such as craters and weak points in the dried film.

What is Foam?

Foam can be described as a stable dispersion of gas bubbles in a liquid medium.

In pure liquids, foam is not stable. Foam is only stable in systems containing surfactants - like substances such as wetting agents, or certain surface control additives needed to improve important properties of the paint; surface active materials tend to migrate to the air/liquid interface of the paint, thereby reducing the surface tension.

Foam originates at various stages of production, such as pumping, stirring, dispersing, and also the application of a liquid paint, through the entrapment of air bubbles. The air-liquid interface of these bubbles is surrounded by the surface-active materials in the paint. Due to the bubbles' low density, they rise to the surface in low-viscosity paints. As the bubbles rise, smaller bubbles can combine to form larger bubbles which rise faster. At the surface, the bubbles accumulate and deform both the surface of the paint and themselves. The air cannot escape because a lamella is formed which is stabilized by the presence of surfactants. Without surfactants, drainage of the liquid would cause thinning of the lamella until breakage occurred.

However, the presence of surfactants prevent lamella thinning by

- counterflow of liquid due to a surface tension difference, as result of interface stretching, called the Marangoni effect.

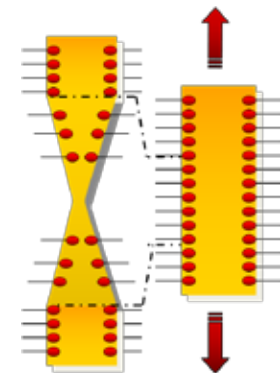
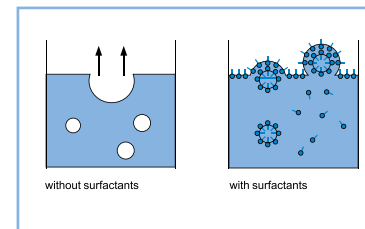

Defoaming

- repulsion by the surfactants at the interfaces, through steric and electrostatic mechanisms. These stabilizing effects result in elasticity of the lamella, preventing them from reaching a critical thickness of ca. 10 nm, which is the criterion for lamella breakage.

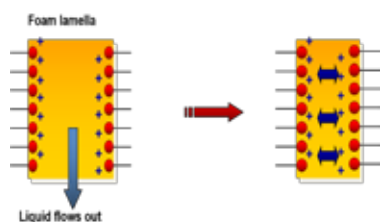

Mode of action

To eliminate the foam defoamers and air release agents do need to fulfil certain conditions:

- Low surface tension** so that it can be concentrate on the boundary layer fluid/ air or gas and then penetrate in the foam, weaken and burst the foam and can also be uniformly dispersed through in the formulation
- Capacity to spread** over the foam bubbles when the paint system is sprayed on the substrate. In this way the defoamer will cover the whole applied surface
- Insoluble in the medium** for a long time. This will ensure the long term stability of the defoamer

But the selection of the defoamer remains to be critical. when for your systems a defoamer will be selected what is too incompatible it will cause other defects to your systems what is unwanted. These defects can be eg. like craters, causing turbidity or loss of gloss, orange peel and many others. Due to many variety of resins and coatings systems one defoamer can't be optimal for all formulations and need to be optimized and selected per systems.

In for defoamers we can make a difference between macro-foam and micro-foam. Macro-foam is foam what appears at the surface of your system. Micro-foam is entrated foam into your system what can't rise fast enough to the surface to be destroyed. for both different defoamers are required. When having micro-foam there is a high need for air-release agents who can coagelate micro bubble to bigger bubbles so the rise faster to the surface. This is described by the Stokes law:

$$v \sim \frac{r^2}{\eta}$$

It describes the speed of the air bubble is related to the diameter of your air bubble divided by the viscosity of your system. In simple words: the bigger the air bubble the faster it will rise to the surface.

Micro-foam defoaming properties can be enhanced by selecting defoamers who may contain hydrophobic particles or polyurea.

How do Defoamers work?

To eliminate foam, these stabilizing effects must be avoided using defoamer(s), which should have one or more of the following properties:

- foam destruction to eliminate existing foam
- foam prevention to avoid formation of foam
- air release to assist an air bubble's to rise to the surface

Defoamers act mainly in the stabilized lamella. Therefore it must be insoluble in the paint system, mobile so that it can enter in the lamella and spread at the interface to displace the surfactants. The defoamer must have a lower surface tension than the surfactant, leading to an opposite Marangoni effect, i.e. fast thinning and collapse of the lamella.

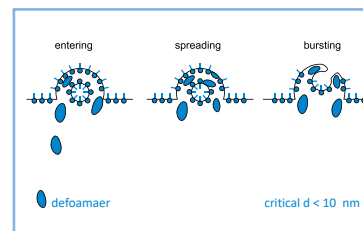

Choosing a Defoamer

Possible chemical entities for defoamers are molecules with a low surface tension such as silicone and mineral oils, fatty acid and fluorocarbons. To increase the defoaming

efficiency, solid particles with a low surface tension can be included, such as hydrophobic silica and metallic soaps. These materials can be incorporated in carriers such as water or organic solvents to promote addition and enable faster distribution of the active substance in the liquid paint. 100% active defoamers are suitable for systems subjected to shear stresses such as grinding, ensuring their distribution and activity as a defoamer.

Different defoamers for different systems:
For solventborne and solvent-free systems

polysiloxanes, polyacrylates and polyolefins are effective, because these types of systems already have a low surface tension. Pure polydimethylsiloxanes can also be used but are critical in terms of their compatibility due to side-effects such as cratering. The best balance between compatibility and incompatibility is achieved through organically-modified polysiloxanes. Modification with fluorine gives even lower surface tensions.

For waterborne systems

a wider range of chemical structures can be used due to the generally higher surface tension of these systems; here mineral oil types and silicones are highly effective.

An important point to consider is the incorporation of the defoamer in the paint system. The defoamer is not soluble in the system, so a good distribution of the active substance is necessary. This should be controlled by the mixing speed and time, otherwise craters can be formed and/or loss of defoaming efficiency is observed.

Wetting and leveling technology



Flow and leveling agents playing a very important role for the superior appearances of your coating. These additives are needed to avoid problems like: orange peel, Bernard cell formation, floating, flooding, craters, fish eyes, fat edge (also called edge crawling). Leveling agents, due to the strong surface tension reduction properties can offer good wetting and leveling. (Fluor modified) Acrylic leveling agents gives good long wave leveling and anti-crater performances. These wetting and leveling agents are offered by UNIQCHEM under the brand of **UNIQ[®]FLOW**.



Wetting

The wetting process is a central feature of paint production.

Surface Tension

The main factor in the wetting process is the surface tension of the various components. In order to understand the origin of the surface tension of a given material, for example a liquid, we have to examine the surface of that material on a molecular basis.

Several attractive forces may exist between single molecules: London, Van der Waals, dipoles, hydrogen-bridges and ionic forces.

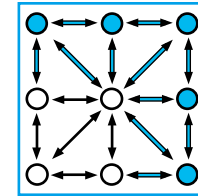

It is even stronger at corners and edges due to less surrounding layers being present.

Wetting Processes

The surface tension of a liquid or a solid can be measured by determining the contact angle. The most practical way to calculate it is by the Patton's equation which takes into account the approximation of the solid's surface tension (critical surface tension).

Successful wetting can be directly related to the size of the contact angle.

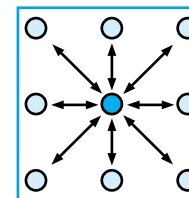

In the bulk of the material every molecule is equally surrounded by other molecules leading to equilibrium of forces.

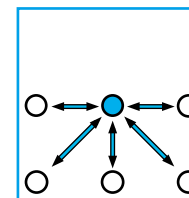
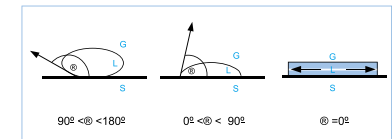

At the surface however, part of the surrounding is missing and therefore all forces are directed into the center of molecules.

At a contact angle $> 90^\circ$ no wetting takes place and the droplet keeps its spherical shape.

At a contact angle $< 90^\circ$ wetting improves and the contact surface (droplet-solids interface) increases.

At a contact angle $= 0^\circ$ the desired spreading is achieved.

This is only possible when the surface tension of the liquid is lower than the surface tension of the solid.

Wetting



That means in the coating industry, that only the liquid can be influenced, as the solids such as pigments and fillers, and also the substrate, have a fixed surface tension.

One example of reducing the surface tension of a liquid is the addition of a surfactant. Accumulation at the surface leads to compensation of tension by interaction of the polar groups. The value obtained for the surface tension is determined by the lower surface tension of the surfactant.

This concept is the basis for solving many problems associated with coatings, such as pigment wetting, and surface defects such as craters, poor flow and foam.

Surface Control

Surface control additives are used to prevent surface defects during paint application and improve resistance and appearance of the dry film.

Surface Defects

Possible surface defects during paint application are:

- Orange Peel
- Pinholes
- Craters
- Fish Eyes
- Edge Crawling
- Air-draft Sensitivity
- Telegraphing
- Floating (Bénard cells)
- Silking

Orange Peel:

This typical appearance of the surface is only observed following spray applications.

Three main factors influence this defect:

- Viscosity of the sprayed liquid
- Spraying conditions such as pressure, air/liquid ratio
- Surface tension of the liquid

The first two factors depend strongly on the operator. The third factor can be controlled by the paint formulator. Lowering the surface tension of the liquid leads to smaller droplets under the same spray conditions and improves the flow of the single droplets after application.

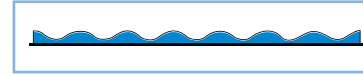

Craters and Pinholes:

Craters and pinholes are caused by liquid or solid contamination present on the substrate or in the paint, or from the surroundings, before the drying process starts. The reason for the formation of craters is the difference in surface tension between the liquid paint and the contaminant. Such defects increase, as surface tension differences grow. By lowering the surface tension of the liquid, such defects can be avoided.

Pinholes are craters, where the liquid has not formed a homogeneous layer, thereby leaving a depression which penetrates to the substrate.

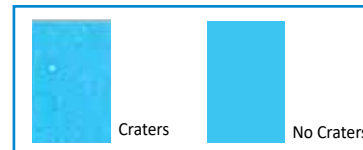

Fish Eyes:

Fish eyes are caused by insufficient substrate wetting. This occurs when the surface tension of the liquid paint is higher than that of the substrate and no spreading takes place on its surface. Spreading is improved by lowering the surface tension of the liquid.



Telegraphing:

Telegraphing (ghosting) occurs, when areas of different surface tension on the substrate are formed by wiping, by residual traces of a cleaning liquid or by finger prints. These marks appear on the surface of the applied paint film. This effect is clearly seen when the substrate/base coat contains interfacial active substances.

Air-draft Sensitivity:

Local differences in surface tension of the paint caused by non-uniform evaporation of the solvent can cause air-draft sensitivity. Locally confined evaporation leads to an increased surface tension in the film. Rupture of the film can take place when this surface tension rises above the substrate's surface tension, and de-wetting takes place. This problem is avoided by lowering the surface tension of the liquid.

Edge Crawling:

Edge crawling is found at the edges of the substrate, because the surface of the applied paint film is larger at the edges. Here faster evaporation of solvents takes place, leading to a stronger increase of surface tension than in the rest of the liquid film. A higher surface tension causes the surface to crawl, because it is trying to adopt a smaller overall size.

This problem is avoided by lowering the surface tension of the liquid.

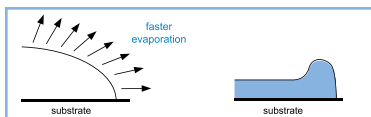

Floating (Bénard cells) and Silking:

Floating and silking are related to processes taking place in the liquid paint during the drying phase. Differences in the density and surface tension give rise to turbulent flow of material from the lower to the upper part of the film. In pigmented systems, the pigments settle in different areas depending on their mobility. On horizontal surfaces, this floating is seen as hexagonal patterns; so-called Bénard cells. Silking has the same origin but is limited to vertical surfaces and shows as line-shaped patterns. These defects can be avoided by minimizing the surface tension differences occurring during the drying process.

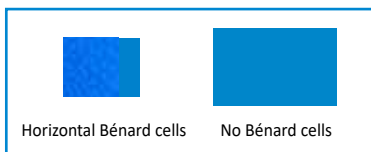

Leveling

All these defects are caused by differences and changes in the surface tensions of the liquid paint, substrate and contaminants.

With “Wetting” it was shown that effective wetting of a solid takes place when the liquid has a lower surface tension than the solid. When the surface tension of the liquid paint is high, the system is more sensitive to wetting defects. In general, modern synthetic resins have a higher surface tension than those based on natural fatty acids. Aqueous systems have a high surface tension due to their polarity.

The main solution to these problems is to adjust the surface tension of the liquid to that of the solid. Therefore additives to improve leveling need a low intrinsic surface tension and a high mobility towards the interface they have to influence.

Slip

An additional requirement for a coating is good slip. This so-called “slip” improves the aesthetic impression and helps to protect the film against scratches, metal marking and dirt. Slip properties are only achieved by using long chain polysiloxanes containing dimethylsiloxane groups. The friction at the surface caused by irregularities is reduced by the lubrication effect of the dimethylsiloxane groups concentrated at the surface, without producing a greasy layer.

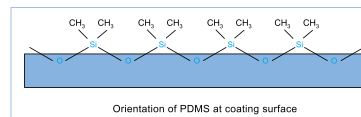

The slip can easily be determined by slip angle measurement or by touch.

Protection by slip is most important in the initial drying stage, where the surface is still vulnerable to mechanical influences. Only a small amount of silicone-leveling agent is needed for the optimum slip performance, whereas over-dosage can lead to unwanted side-effects.

A common unwanted side-effect of some polyether-modified siloxanes is their surface-activity, sometimes giving rise to foam stabilization. Often, therefore, the simultaneous use of a defoamer is recommended.

Alternatively, an alkyl-modified siloxane or polyacrylate can be used as leveling agent to avoid foam formation during paint application.

Leveling Agents

The UNIQCHEM range of slip and leveling agents are based on the following chemical families:

- Long chain polysiloxanes are the most common leveling agents in the coating industry. Pure polydimethyl siloxanes are not used in the UNIQCHEM range due to their incompatibility with many resins. To improve this, the polydimethyl siloxane backbone is modified with alkyl or polyether side chains. In addition, reactive groups such as isocyanates, double bonds, hydroxyl groups and acid groups can be incorporated, leading to the advantage that the leveling agent can be crosslinked into the film. They are suitable for solventborne systems, waterborne systems or both, depending on the type of side-chain used.

- Polyacrylates are produced from special monomers with a low surface tension. These structures move to the interface, equalizing the surface tensions.

They are known for not causing inter-coat adhesion problems in the dry film, and depending on their modification, they can be used in solvent- or waterborne systems.

- Short chain polysiloxanes were developed to bring silicone-based leveling agents which will not affect inter-coat adhesion. The main benefit is found in water-based system.



Dispersing technology

Dispersing agents playing a very important role for the wetting and stabilization of pigments. The faster the wetting is taking place the faster the stabilization can take place. In this process it is important to be able to reduce the particle size back to the primary particle of the pigment. Then you will achieve the maximum color strength. Very good dispersing agents will offer you very good viscosity reduction, color strength, reduction in processing time. These Wetting and dispersing agents are offered by UNIQCHEM under the brand **UNIQ[®] SPERSE**.

Dispersing technology

By the preparation of colored paint, a good dispersion quality is one of the most difficult factors. The dispersion process consists of converting dry pigments into pigment dispersion, which must be fine and sufficiently stable to achieve the final coloristic properties and stability. This is a complex process there resin, type of pigment, solvents and the use of dispersing agents are playing here an important role.

1. Dispersion process

High saturation and colouring properties of high quality coatings are characterized by good dispersion of pigments, optimization of particle size and long-term stability.

The dispersion process of a pigment in liquid coatings can be divided into the three processes:

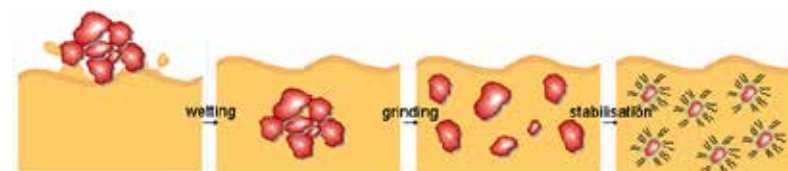

Pigment wetting: The air and moisture covering the pigment is replaced by the resin solution. The solid/gas interface (pigment/air) is transformed into a solid/liquid interface (pigment/resin solution).

Grinding stage: By high shear forces the pigment agglomerates are broken up into smaller units, preferable primary particles.

Stabilisation: The pigment dispersion is stabilized by dispersing agents in order to prevent the formation of uncontrolled flocculates. The resultant suspension is stabilized due to the adsorption of binder species or molecules at the pigment surface.

Dispersing additives, which adsorb on the pigment surface, facilitate liquid/solid interfacial interactions and help to replace the air/solid interface by a liquid medium/solid interface.

The grinding process can be regarded as a de-flocculation process. In the absence of stabilizing agents, effects such as reduced color strength, decreased gloss, and altered rheology may occur.

1.1 Stabilizing of Pigment dispersion

The pigment dispersion what is achieved in the last step will be used later in the let down system where it should stay stable during storage and later during the application and film formation.

Stability of pigment concentrates or actually preventing pigment particles to re-agglomerate again is depending on the dispersing agent. The distance between 2 particles needs to be big enough that they can repulse each other.

There are two principal mechanisms for the stabilization of pigmented dispersions described:

1.1.1 Electrostatic stabilization is only working in a water based application. When two particles having the same charges approaching each other will result in a repelling effect. The resulting Coulomb-repulsion of the charged particles allows the system to remain stable.

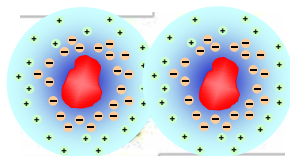

1.1.2 Steric stabilization suited for water and solvent based systems is when pigments are sterically stabilized (the surface of the solid particles are completely covered by polymers) making particle-to-particle contact impossible. Strong interactions between polymers and solvents (organic solvent or water) prevent the polymers from coming too closely into contact with one another (flocculation).

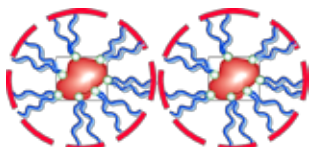

Steric stabilization relies on the adsorption of a layer of resin or polymer chains on the surface of the pigment.

One fundamental requirement of steric stabilization is that the chains are fully solvated by the medium. This is important because it means the chains will be free to extend into the medium. In systems where the chains are not so well solvated they will prefer to lie next to each other on the surface of the pigment, providing a very much smaller barrier to inter-particulate attraction what will result in much easier flocculation.

2 Dispersants Families

The choice of the dispersing agents for the pigment stabilization is a key issue in the coating and ink industry. Formulators have to find the most suitable products for their formulation taking into account the final application of their coating, the coating system (water based, solvent based, etc.) and the other additives.

The role of the dispersing agents is to enhance the dispersion process and ensure a fine particle size in order to stabilize pigments in the resin solution. As explained earlier, an efficient dispersant has to perform the three main functions: pigment wetting, dispersing, and stabilizing. Dispersing agents generally differ for aqueous and solvent-based coatings.

In term of chemical structure one can divide dispersing agents into the two following classes:

- Surfactants, also called low molecular weight dispersing agents
- Polymeric dispersants, also called high molecular weight dispersants

The main differences of those two types of dispersants being the molecular weight, the stabilization mechanism and the resulting let down stability.

In addition polymeric dispersing agents have multiple anchor groups where surfactant like dispersing agents more related to a polar head with a side chain for the compatibility.

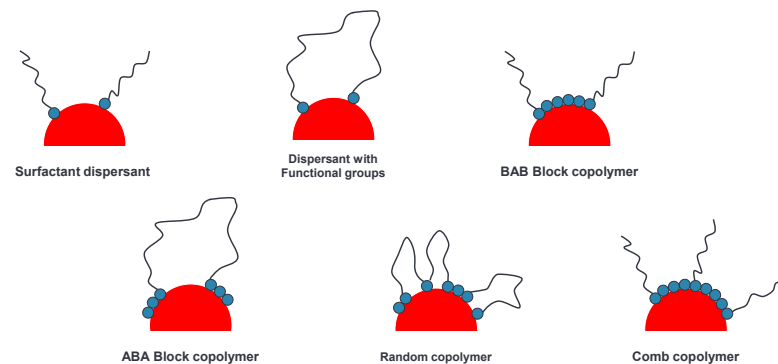

2.1 Polymeric dispersants

Polymeric dispersants stabilize paints, coatings and ink systems via a steric stabilization mechanism.

They must have specific anchor groups capable of being strongly adsorbed into the particle surface and must contain polymeric chains that give steric stabilization in the required solvent or resin solution system.

Polymeric dispersants differentiate themselves from the other types of dispersing agents through considerably higher molecular weights. Because of its structural features, a polymeric dispersant is bound to numerous sites at the same time, forming durable adsorption layers upon many pigment particles. Optimal steric stabilization is achieved when the polymer chains are well solvated and properly stretched, therefore they must be highly compatible with the surrounding resin solution. If this compatibility is obstructed, the polymer chains collapse causing the steric hindrance and the resulting stabilization to be lost.

In order for additives to be effective, the adsorption into the pigment surface must be durable and permanent. The surface properties of the pigment particles are therefore crucial to the additive's effectiveness:

With pigments possessing high surface polarities, such as inorganic pigments that are ionically constructed, the adsorption of any dispersing additive is relatively easy.

However, for pigments with nonpolar surfaces, such as organic pigments whose crystals are composed of nonpolar individual molecules, a proper adsorption is rather difficult to obtain with conventional additives. The wide range of anchor groups that polymeric dispersants provide make them very efficient to anchor on pigments with nonpolar surfaces.

In the traditional method of stabilizing pigments in water, the stabilizing charges used are often disturbed by impurities, such as other ions, or the presence of other pigments with different zeta-potentials. This leads to a destabilizing effect, caused by the reduction of the repulsive forces. Steric stabilization can avoid this issue, making polymeric dispersants very useful for dispersing all types of pigments, even the organic ones that are very difficult to be deflocculated by traditional wetting and dispersing additives.

The nature of the polymeric chain is critical to the performance of polymeric dispersants. If the chains are not sufficiently solvated, then they will collapse on to the pigment surface allowing the particles to aggregate or flocculate. The need for compatibility with the medium extends throughout the final drying stages of any applied coating. If it ceases to be compatible, flocculation may occur leading to a decrease of surface properties such as losses in gloss and tinting strength, etc.

The molecular weight of the polymeric dispersants must be sufficient to provide polymer chains of optimum length to overcome Van der Waals forces of attraction between pigment particles:

Finally, for good surface coating properties and performances, the polymer must be fully compatible with the coating resin after the solvent has evaporated off and the resin has been cross-linked.

2.2 Low molecular weight dispersant (Surfactants)

Surfactant dispersants are conventional low molecular weight dispersing agents. Surfactant molecules are able to modify the properties and, in particular, they lower the interfacial tension between the pigment and the resin solution.

This surface activity arises because the surfactants' structure consists of two groups of contrasting solubility or polarity. In aqueous systems, the polar group is known as a hydrophilic group and the non-polar group as hydrophobic or lipophilic. In non-aqueous systems, the polar group is known as the oleophobic group and the non-polar group as oleophilic. Surfactants are classified according to their chemical structure and, more specifically, their polar group: anionic, cationic, electroneutral and non-ionic.

ANIONIC COMPOUNDS

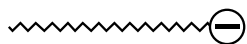

ANIONIC

e.g sodium oleate

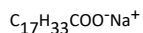

CATIONIC COMPOUNDS

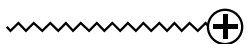

CATIONIC

e.g. oleylamine

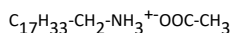

ELECTRONEUTRAL COMPOUNDS



ELECTRONEUTRAL

e.g. oleylamine oleate

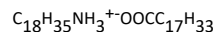

NON-IONIC

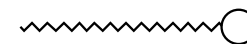

NON-IONIC

e.g. aliphatic polyether

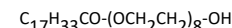

As with the polymeric dispersing agents, their effectiveness is determined by:

- The absorption of the polar group onto the pigment surface. The anchoring groups can be amino, carboxylic, sulfonic, phosphoric acids or their salts.
- The behaviour of the nonpolar chain in the medium surrounding the particle. This part of the molecule (aliphatic or aliphatic-aromatic segments) must be highly compatible with the binder system.

The stabilization mechanism of surfactant-like dispersing agents is electrostatic: the polar groups forming an electrical double layer around the pigments particles. Due to the Brownian movement the pigment particles frequently encounter each other in the liquid medium thus having a strong tendency to re-flocculate on the let down stage.

Because of their chemical structure (eg: low molecular weight) and the electrostatic method of stabilization, surfactants may cause the following defects:

- Water sensitivity: Surfactants generally have a tendency to provide water sensitivity to the final coating, thus making them inappropriate for use in outdoor applications.
- Foam formation: Many surfactants generate foams which lead to surface defects (eg. fish eyes, craters) on the final coating. If foaming occurs at the milling stage it can also cause a loss of production capacity.
- Interference with intercoat adhesion.

Over the past years specific surfactants have been developed to minimize these defects, and some provide other advantages to the final paints such as defoaming/deaeration or difficult substrate wetting.

The most widely used surfactants for pigment dispersion in coating formulations are:

- Fatty acid derivatives
- Phosphate esters
- Sodium polyacrylates / polyacrylic acid
- Acetylene diols
- Soya lecithin

Main differences between LMW dispersant and HMW dispersant:

	Conventional wetting and dispersing agents	HMW polymeric dispersing agents
General Main Effect	<ul style="list-style-type: none"> •Reduce surface tension to facilitate wetting during grinding process. •Using difference in charges to perform the anchoring process •Using repulsion of same charges and attraction of different charges for stabilization 	<ul style="list-style-type: none"> •Reduce surface tension to facilitate wetting during grinding process •NOT using difference in charges to perform the anchoring process •Use steric hindrance for stabilization
Chemistry	Low molecular weight surfactant, most of the time contain ionic group as pigment affinity	Functional copolymer with special pigment affinity group
Molecular weight	500 – 2000 g/mol	4000 – 25000 g/mol
Dosage, solid dispersant on pigment (SOP)	0.2 – 5 %	1 – 60 %

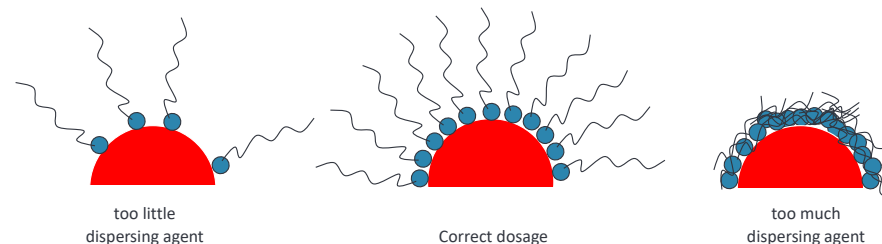

As a general rule, 2-2.5 mg of polymeric dispersant, per square meter of pigment surface area will be close to the optimum amount required.

$$\text{Solid dispersant on pigment (SOP)} = \frac{\text{Pigment surface area}}{4 - 5}$$

A ladder series of polymeric dosage levels should be evaluated based around this 2-2.5 mg/m² level. Measurement of dispersion viscosity will show a minimum at the optimum dosage; although it is also possible to measure gloss or colour strength of the coating which will show a maximum at the same optimum dosage.

3 Required amount of dispersant.

Dispersing agents are not just additives to conventional mill-bases. The choice of the most suitable dispersing agents is sometimes difficult and their usage require sometimes specific guidelines.

The choice of dispersant is also related to the surface nature of the pigment. The polarity of the surface of the pigment differs from organic (non-polar) to inorganic (more polar), and this means that the nature of the dispersant anchor group is critical for optimum absorption. The choice of anionic anchor group (acidic value) should allow for better performance with inorganic pigments and a cationic anchor group (amine value) should be more appropriate for organic pigments.

The surface area of the pigment also affects the level of dispersant used, and in general, if too little is used then the full benefits will not be realized. If too much is used, it can be shown that the thickness of the protective barrier is actually reduced as a result of overcrowding on the pigment surface. Therefore the use of an excess level of dispersant actually leads to final coating properties which are inferior to those obtained with an optimized dosage.

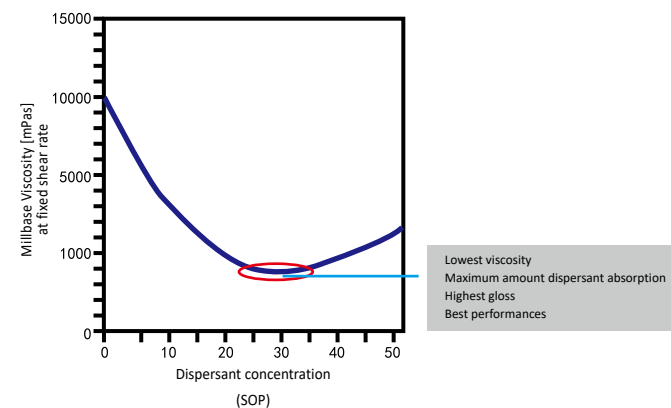

Light Stabilizers Theory

Coatings used to beautify and protect base materials must themselves be protected from potentially harmful environmental elements such as heat, oxygen, water and especially light. Although many polymers do not absorb ultraviolet radiation directly, all coatings contain some components that may absorb UV light, initiating oxidative degradation of the polymer.

Ultraviolet radiation—the most common source is the sun—can lead to decreased performance and undesirable appearance changes in coatings. Artificial light can cause similar changes. UV radiation can cause harm by breaking down the chemical bonds in a polymer's structure. This degrades the binder and can lead to such changes as cracking, checking, loss of gloss, chalking, pigment fading, delamination or peeling, yellowing, corrosion and loss of physical and protective properties of the coating. This chemical process is photo-oxidation.

Process of photo-oxidation by UV Radiation

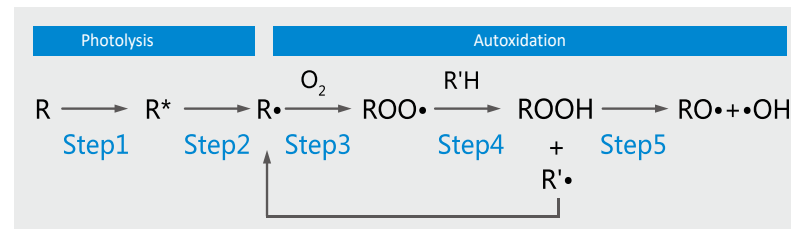

Photo-oxidation is two distinct processes. The first is photolysis, a complex process occurring in several steps, which involves the absorption of UV radiation, followed by the formation of free radicals due to the breaking of molecular bonds. The second is autoxidation. Here, the free radicals formed during photolysis interact with oxygen to form peroxy radicals.

There are five separate steps during photo-oxidation. In the schematic at below, R represent the coating binder or UV absorbing component.

Step1



Coating absorbs UV radiation. The energy from the absorbed UV radiation “excites” the absorbing species (either binder molecules or impurities) and raises them to a higher energy level (R^*). These excited state molecules are very reactive and may undergo a wide range of processes. Two common processes are return to the ground state or homolytic bond cleavage.

Light Stabilization technology

UNIQ®LIGHT is the brand for our light stabilizers suitable for wood-, plastic-, industrial-, coil-, and automotive coatings. These products can improve the weather resistance of coatings.

Light Stabilizers Theory



Step2



If the molecule cannot be brought to its ground state, hemolytic bond cleavage and the formation of free radicals($R\cdot$) will occur.

Step3

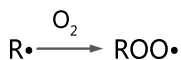

The free radicals formed during photolysis readily react with oxygen to form peroxy radicals. This is called autoxidation.

Step4

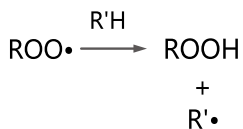

The peroxy radicals attack the polymer backbone($R'H$) via hydrogen abstraction, forming hydroperoxides and more free radicals. These free radicals again readily react with oxygen in Step 3 to form additional peroxy radicals.

Step5



The hydroperoxides, which are very unstable to both UV radiation and heat, fragment and form additional free radicals. As the processes continue, more and more molecular bonds break, leading to a deterioration of the desired coating properties.

Types of light stabilizers

There are two types of light stabilizers. One is UV absorber which is to absorb harmful UV light to protect the coating. The other is hindered amine light stabilizer which is to capture free radicals to avoid coating degradation.

- **UV absorbers** is to absorb UV light in competition with the chromophores which are part of the polymer backbone to prevent degradation. They are colorless or almost colorless additives, which have a strong absorbability in the ultraviolet part of the spectrum. UV absorbers can dissipate light energy as thermal energy.

Light Stabilizers Theory



- **Hindered Amine Light Stabilizers(HALS)** is to capture free radicals before subsequent reactions leading to degradation can take place. HALS can impede thermo-oxidation. The polymer contains the HALS will still keep the resistance to photo-degradation even run of the HALS. The explanation for this phenomenon is that HALS' oxidation products, such as hydroxyl-amine and aminoether, can inhibit photo-degradation. Hydroxyl-amine and aminoether are all able to capture peroxide free radicals.

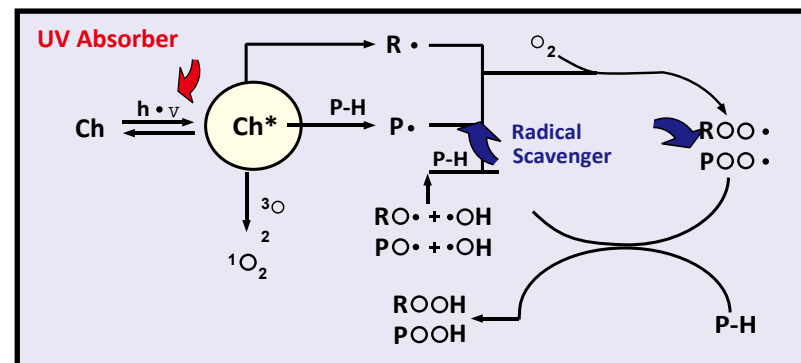



Additives for the Coating Industrie

UNIQ[®] FOAM

for coating industrie

UNIQ[®] FOAM 120 S

Solution of non-silicone defoaming polymers

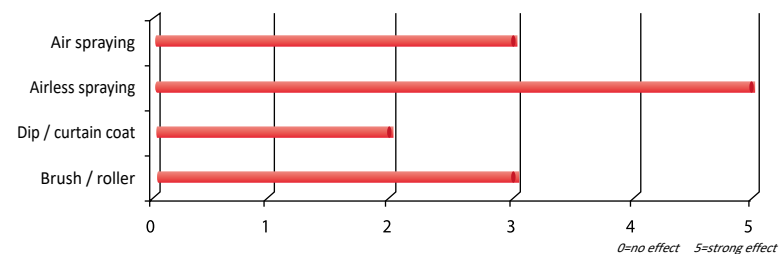

UNIQ[®]FOAM 120 S is a strong defoamer suitable for all solvent borne coating systems. It prevents the formation of foam during the manufacture and filling.

The additive has an immediate foam-destroying effect and does not have influence on the intercoat adhesion. Due to the strong defoaming performances, the product is less suitable for high gloss clear coatings. Influence of transparency in clear systems should be evaluated.

Special Features

- Solvent-borne applications
- Strong defoaming effect
- Does not interfere intercoat adhesion
- Silicone-free
- Heat stable

Application

Architectural coatings	■
Wood and furniture coatings	■
Automotive and refinish coatings	■
Can/coil coatings	■
Industrial coatings	■

highly recommended ■
recommended □

Product Specification

Density 20° C	0.8 g/cm ³
Flashpoint	30°C
Color	Max. 1
Appearance	Slight yellowish liquid

Addition levels

- Based on total formulation: 0.1 – 1.0 %

Added in grinding stage or under high shear forces incorporation.

Due to its strong incompatibility, the influence upon the transparency of clear systems or other surface defects must be evaluated.

Packaging

- 22 kg
- 150 kg

Shelf life

UNIQ[®]FOAM 120 S should be stored in a cool dry place. When kept in an original unopened container, it will keep up to 5 years from the date of manufacture.

UNIQ® FOAM 130 S

Solution of non-silicone defoaming polymers



UNIQ® FOAM

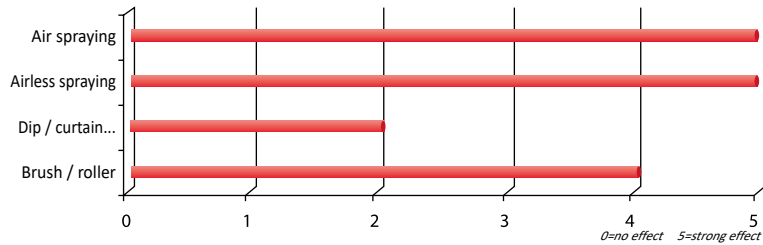

UNIQ® FOAM 130 S is very strong defoamer based on acrylic polymer (polyvinyl ether), showing superior de-aerating effects. Suitable for all solvent based paints, to be used in various thermo-setting- and air-drying paints. Applications include architectural paints, floor coats, heavy duty paints, auto-refinishes, coil coatings and car OEM.

UNIQ® FOAM 131 S

Solution of non-silicone defoaming polymers

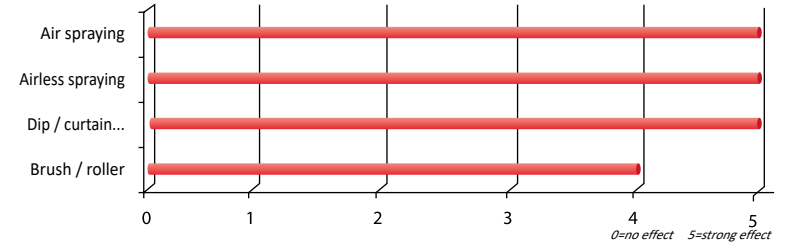

UNIQ® FOAM 131 S is strong defoamer mainly suitable for pigmented coating systems. Due the chemical structure the product will not cause turbidity, but will over good air-release and macro defoaming properties. The product is well suited for spraying applications.

Special Features

- Strong defoamer
- Suitable for pigment systems
- Suitable for high viscosity and high solid coating systems
- Does not interfere intercoat adhesion
- Silicone-free
- Heat stable

Application

Architectural coatings	■
Wood and furniture coatings	■
Automotive and refinish coatings	■
Can/coil coatings	■
Industrial coatings	■

highly recommended ■
recommended □

Special Features

- Strong defoamer
- Suitable for pigment systems
- Suitable for high viscosity and high solid coating systems
- Does not interfere intercoat adhesion
- Silicone-free
- Heat stable

Application

Architectural coatings	■
Wood and furniture coatings	■
Automotive and refinish coatings	■
Can/coil coatings	■
Industrial coatings	■

highly recommended ■
recommended □

Product Specification

Density 20°C	0.9 g/cm ³
Color	Max. 1
Appearance	Slight yellowish clear transparent

Addition levels

- Based on total formulation: 0.1 – 1.0 %

Due to its strong incompatibility, the influence upon the transparency of clear systems or other surface defects must be evaluated.

Product Specification

Density 20°C	0.94 g/cm ³
Color	Max. 1
Appearance	Yellowish transparent

Addition levels

- Based on total formulation: 0.1 – 1.0 %

Due to its strong incompatibility, the influence upon the transparency of clear systems or other surface defects must be evaluated.

Packaging

- 25 kg
- 170 kg

Shelf life

UNIQ® FOAM 130 S should be stored in a cool dry place. When kept in an original unopened container, it will keep up to 3 years from the date of manufacture.

Packaging

- 25 kg
- 170 kg

Shelf life

UNIQ® FOAM 131 S should be stored in a cool dry place. When kept in an original unopened container, it will keep up to 5 years from the date of manufacture.

UNIQ® FOAM 132 S

Silicone free defoamer



UNIQ® FOAM

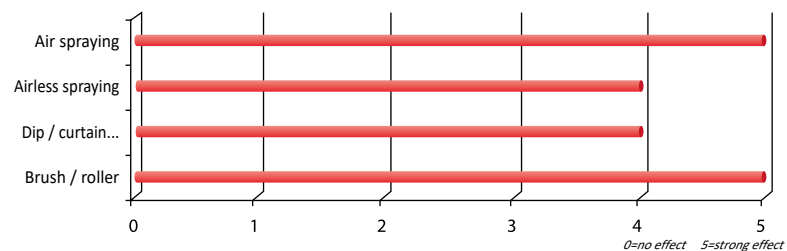

UNIQ® FOAM 132 S is medium to strong defoamer to be used in clear coatings as well suitable for pigmented coating systems. Due the chemical structure the product will not cause turbidity, but will give good air-release and macro defoaming properties. Also very well suited for UPE primers remaining high clarity and transparency. The product is well suited for spraying applications.

Special Features

- Strong defoamer
- Suitable for clear coats and pigmented coatings systems
- Does not interfere intercoat adhesion
- Silicone-free
- Heat stable

Application

Architectural coatings	■
Wood and furniture coatings	■
Automotive and refinish coatings	■
Can/coil coatings	■
Industrial coatings	■

highly recommended ■
recommended □

Product Specification

Density 20°C	0.98 g/cm ³
Color	Max. 1
Appearance	Yellowish transparent

Addition levels

- Based on total formulation: 0.1 – 1.0 %

Packaging

- 25 kg
- 180 kg

Shelf life

UNIQ® FOAM 132 S should be stored in a cool dry place. When kept in an original unopened container, it will keep up to 5 years from the date of manufacture.

UNIQ® FOAM 150 S

Solution of non-silicone defoaming polymers

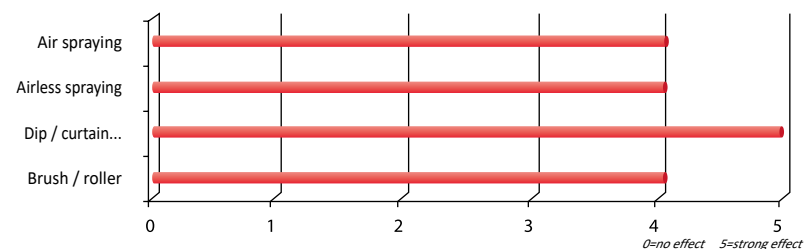

UNIQ® FOAM 150 S is a strong defoamer can be used for all solvent borne coating systems, especially suitable for solvent free epoxy and solvent free UV system. The additive has an immediate foam-destroying effect with very strong deaeration and does not have influence on the intercoat adhesion. With epoxy resin the defoamer can give slight haziness, but as soon the hardener is added the products becomes fully clear. Therefore the product is suited for pigmented and non pigmented systems.

Special Features

- Solvent-borne and solvent free applications
- Strong defoaming and deaeration effect
- Does not interfere intercoat adhesion
- Silicone-free
- Heat stable

Application

Architectural coatings	□
Wood and furniture coatings	■
Automotive and refinish coatings	■
Can/coil coatings	■
Industrial coatings	■

highly recommended ■
recommended □

Product Specification

Density 20°C	1.05 g/cm ³
Color	Max. 3
Appearance	Clear colorless liquid

Addition levels

- Based on total formulation: 0.1 – 1.0 %
Can be added in any stage of the formulation.

Due to its strong incompatibility, the influence upon the transparency of clear systems or other surface defects must be evaluated.

Packaging

- 25 kg
- 190 kg

Shelf life

UNIQ® FOAM 150 S should be stored in a cool dry place. When kept in an original unopened container, it will keep up to 5 years from the date of manufacture.

UNIQ® FOAM 152 S

Silicone free polymer defoamer



UNIQ® FOAM

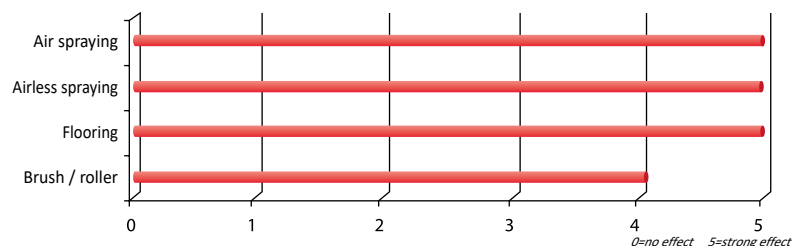

UNIQ® FOAM 152 S is a strong silicone free defoamer can be used for all solvent borne coating systems, especially suitable for solvent free self-leveling epoxy system. The additive has an immediate foam-destroying effect with very strong deaeration and does not have influence on the intercoat adhesion. At the same time, it will help to maintain the good film appearance by the additional leveling properties in high gloss systems and will give good clarity.

UNIQ® FOAM 170 S

Solution of non-silicone defoaming polymers

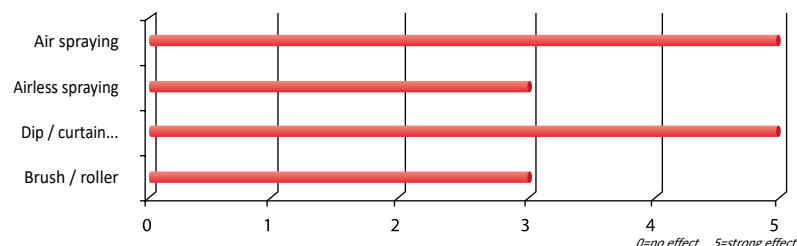

UNIQ® FOAM 170 S is a strong anti-foam and air-release agent especially suitable for use in unsaturated polyesters, baking coatings, epoxies and acrylic/vinyl acetate combinations. The additive furthermore helps to improve the leveling.

Special Features

- Quick de-aeration and defoaming effect for pigmented and non pigmented solvent free coating system
- Does not interfere intercoat adhesion
- Excellent film appearances
- Silicone-free
- Heat stable

Application

Architectural coatings	
Wood and furniture coatings	■
Automotive and refinish coatings	□
Industrial coatings	■
Protective coatings	■

highly recommended ■
recommended □

Special Features

- Quick de-aeration and defoaming effect for thermosetting resin system
- Suitable for pigment loading coating systems
- does not interfere intercoat adhesion
- Silicone-free
- Heat stable

Application

Architectural coatings	□
Wood and furniture coatings	■
Automotive and refinish coatings	■
Can/coil coatings	■
Industrial coatings	■

highly recommended ■
recommended □

Product Specification

Density 20°C	0.92 g/cm ³
Refractive index	1.480
Color	Max. 1
Appearance	Slight hazy colorless liquid

Addition levels

- Based on total formulation: 0.1 – 1.0 %
Can be added in any stage of the formulation.

Although the product may be slightly turbid, this cannot be observed anymore in the final dry film.

Product Specification

Density	0.83 g/cm ³
Color	Max. 1
Appearance	Slightly hazy colorless liquid

Addition levels

- Based on total formulation: 0.1 – 1.0 %

Added in grinding stage or under high shear forces incorporation.

Packaging

- 22 kg
- 170 kg

Shelf life

UNIQ® FOAM 152 S should be stored in a cool dry place. When kept in an original unopened container, it will keep up to 5 years from the date of manufacture.

Packaging

- 25 kg
- 170 kg

Shelf life

UNIQ® FOAM 170 S should be stored in a cool dry place. When kept in an original unopened container, it will keep up to 5 years from the date of manufacture.

UNIQ® FOAM 175 S

Solution of non-silicone defoaming polymers

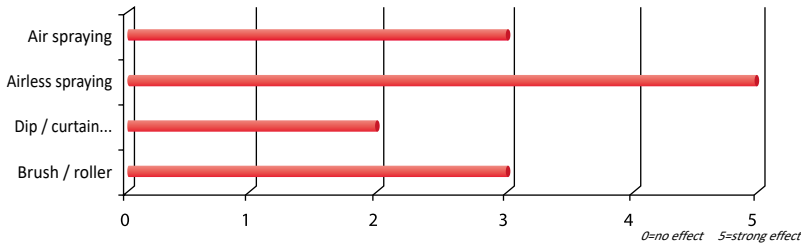

UNIQ® FOAM 175 S is especially effective in wood and furniture coatings based on glossy polyester, paraffin polyester, and in radiation curable polyester. The additive allows curtain coaters to maintain curtain stability even when only thin layers are applied. When using non-pigmented systems, a slight turbidity may be visible over dark wood. Good results were also found with epoxy systems.

Special Features

- Solvent borne and solvent free applications
- Suited for UV coating
- Anti-foam and deaeration additive
- Does not interfere intercoat adhesion
- Silicone-free
- Heat stable

Application

Architectural coatings	<input type="checkbox"/>
Wood and furniture coatings	<input checked="" type="checkbox"/>
Automotive and refinish coatings	<input checked="" type="checkbox"/>
Can/coil coatings	<input type="checkbox"/>
Industrial coatings	<input type="checkbox"/>

highly recommended ■
recommended □

Product Specification

Density 20°C	0.88 g/cm ³
Color	Max. 1
Appearance	Clear slightly yellowish liquid

Addition levels

- Based on total formulation: 0.1 – 1.0 %

Due to its slight incompatibility, the influence upon the transparency of clear systems or other surface defects must be evaluated.

Packaging

- 25 kg
- 170 kg

Shelf life

UNIQ® FOAM 175 S should be stored in a cool dry place. When kept in an original unopened container, it will keep up to 5 years from the date of manufacture.

UNIQ® FOAM 180 W

Water based leveling and anti-popping agent

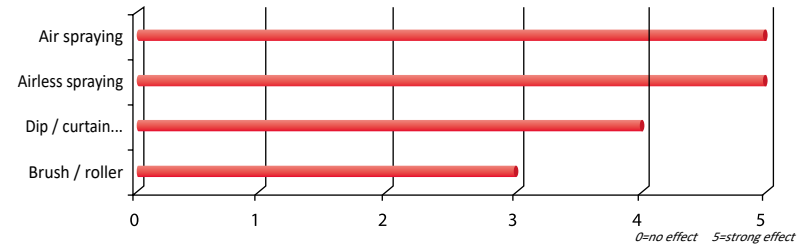

UNIQ® FOAM 180 W is a silicone-free surface additive for aqueous coatings to prevent surface defects such as cratering, scarring, bubbles, pinholes, orange peel and boiling marks and to improve leveling.

Special Features

- Water based applications
- Improve leveling
- Anti-foam and anti-popping in baking system
- Silicone-free
- Heat stable

Application

Architectural coatings	<input checked="" type="checkbox"/>
Wood and furniture coatings	<input checked="" type="checkbox"/>
Automotive and refinish coatings	<input checked="" type="checkbox"/>
Can/coil coatings	<input checked="" type="checkbox"/>
Industrial coatings	<input checked="" type="checkbox"/>

highly recommended ■
recommended □

Product Specification

Density 20 °C	0.81 g/cm ³
Appearance	clear liquid

Addition levels

- Based on total formulation: 0.3 – 3.0 %

Added in grinding stage or under high shear forces incorporation.

Packaging

- 20 kg
- 150 kg

Shelf life

UNIQ® FOAM 180 W should be stored in a cool dry place. When kept in an original unopened container, it will keep up to 2 years from the date of manufacture. At low temperature the product may become turbid, this will not affect the product performances.

UNIQ® FOAM LP2507

Water based silicone free defoamer



UNIQ® FOAM

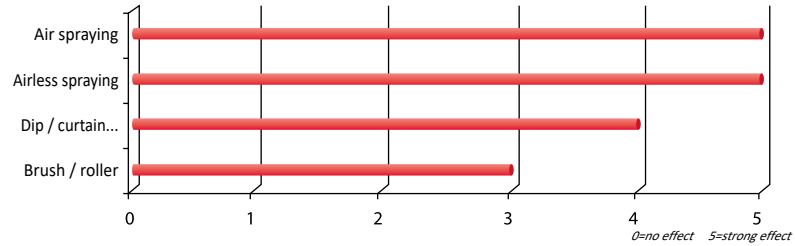

UNIQ® FOAM LP2507 is a strong defoamer/anti-foam based on organic polymers, this product can be used for grinding and spraying conditions. Working well against macro-foam, but delivers also strong micro-foam destroying properties. It is well suited for all water based systems and pigment concentrates.

UNIQ® FOAM LP2537

Water based silicone free emulsion defoamer

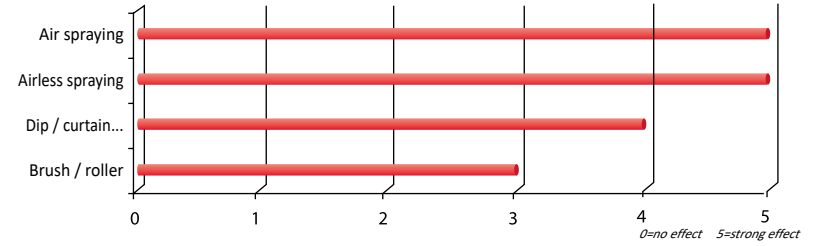

UNIQ® FOAM LP2537 is a silicone-free surface emulsiondefoamer for aqueous coatings for main application of architectural

Special Features

- Water based applications
- Strong defoamer/anti-foam
- Long term persistent
- Silicone-free
- Heat stable

Application

Architectural coatings	□
Wood and furniture coatings	■
Automotive and refinish coatings	■
Can/coil coatings	■
Industrial coatings	■

highly recommended ■
recommended □

Special Features

- Workable pH range 4.0-9.0
- Can be added in all stages
- Also suited for grinding processes
- Silicone free

Application

Architectural coatings	■
Wood and furniture coatings	□
Automotive and refinish coatings	
Can/coil coatings	
Industrial coatings	□

highly recommended ■
recommended □

Product Specification

Density 20 °C	0.99 g/cm ³
Color	Max. 1
Appearance	clear liquid

Addition levels

- Based on total formulation: 0.3 – 3.0 %
- Added in grinding stage or under high shear forces incorporation.

Product Specification

pH	7.0 – 8.5
Density	1.02 g/cm ³
Appearance	white ivory liquid

Addition levels

- Based on total formulation: 0.1 – 1.0 %
- Added in grinding stage or under high shear forces incorporation.

Packaging

- 25 kg
- 200 kg

Shelf life

UNIQ® FOAM LP2507 should be stored in a cool dry place. When kept in an original unopened container, it will keep up to 3 years from the date of manufacture. At low temperature the product may become turbid, this will not affect the product performances.

Packaging

- 30 kg
- 200 kg

Shelf life

UNIQ® FOAM LP2537 should be stored in a cool dry place between 5 and 35 °C. When kept in an original unopened container, the shelf life is 2 years from the date of manufacture.

UNIQ® FOAM 235 S

Silicone defoamer with modification of fluorocarbon



UNIQ® FOAM

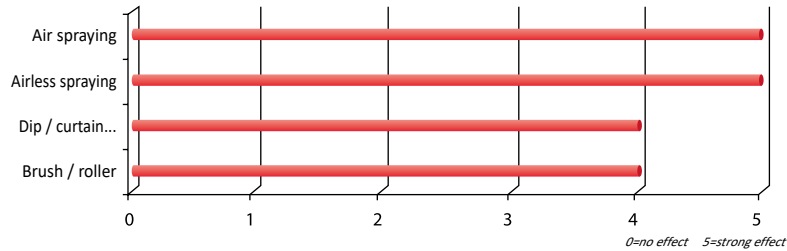

UNIQ® FOAM 235 S is recommended for roller, brush and conventional spray application, very suitable also for systems ranging from low polar to high polar with strong working in against micro-foam. The defoamer is highly effective for solvent based and solvent free coating systems, which offers optimal defoaming at a very low percentage.

UNIQ® FOAM 238 S

Silicone defoamer Suitable for clear coating applications

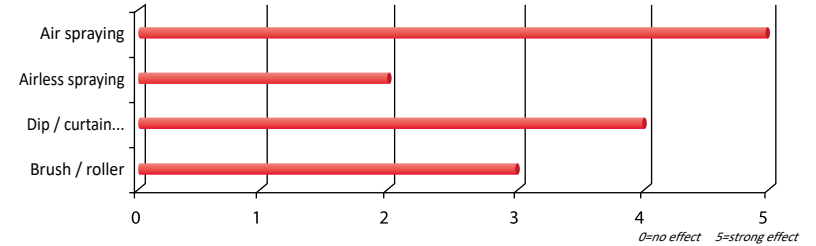

UNIQ® FOAM 238 S is an air release agent to prevent foam and bubbles during the manufacture and application clear coatings for wood- and car refinish applications based on polyurethane resins. The product offers a very high clarity and will not cause haziness in the dry film.

Special Features

- suited for medium viscosity for spray, brush and roller application
- Well suited for curtain coating applications
- micro foam destroying properties
- rather good compatibility

Application

Architectural coatings	■
Wood and furniture coatings	■
Automotive and refinish coatings	■
Can/coil coatings	□
Protective coatings	■

highly recommended ■
recommended □

Special Features

- Highly recommended for high gloss clear coating
- Excellent compatibility
- Effect to eliminate foam and pinholes from production and application
- High transparency
- Doesn't cause haziness

Application

Architectural coatings	□
Wood and furniture coatings	■
Automotive and refinish coatings	■
Can/coil coatings	□
Industrial coatings	■

highly recommended ■
recommended □

Product Specification

Density 20 °C	0.81 g/cm ³
Refractive index	1.415
Color	Max. 1
Appearance	Clear transparent liquid

Addition levels

- Based on total formulation: 0.1 – 0.6 %
Added before grinding.

Product Specification

Density 20 °C	0.88 g/cm ³
Refractive index	1.490
Appearance	Clear colorless liquid

Addition levels

- Based on total formulation: 0.1 – 0.7 %
Added end of the preparation.

Packaging

- 22 kg
- 150 kg

Shelf life

UNIQ® FOAM 235 S should be stored in a cool dry place. When kept in an original unopened container, it will keep up to 5 years from the date of manufacture.

Packaging

- 25 kg
- 170 kg

Shelf life

UNIQ® FOAM 238 S should be stored in a cool dry place. When kept in an original unopened container, it will keep up to 5 years from the date of manufacture.

UNIQ® FOAM 245 S

Silicone defoamer with modification of fluorocarbon



UNIQ® FOAM

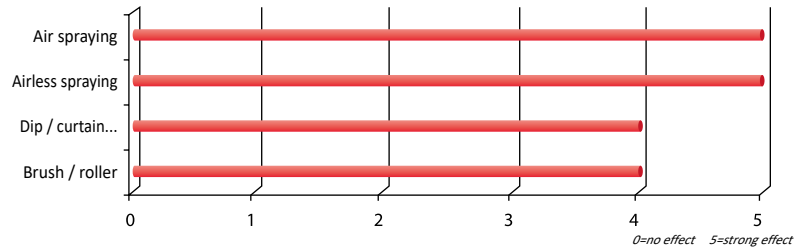

UNIQ® FOAM 245 S is recommended for roller, brush and conventional spray application, very suitable also for systems ranging from low polar to high polar with strong working in against micro-foam. The defoamer is highly effective for solvent based and solvent free coating systems, which offers optimal defoaming at a very low percentage.

UNIQ® FOAM 272 S

Solution of silicone defoaming polymers

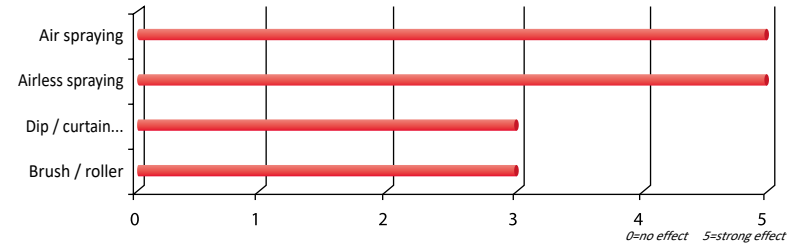

UNIQ® FOAM 272 S is a strong anti-foam and air-release agent especially suitable for use in unsaturated polyesters, epoxies and acrylic resin systems. The product is especially suitable for self-leveling epoxy systems where it will give very fast air-release and defoaming properties. The additive furthermore helps to improve the leveling.

Special Features

- suited for medium viscosity for spray, brush and roller application
- Well suited for curtain coating applications
- micro foam destroying properties
- rather good compatibility

Application

Architectural coatings	■
Wood and furniture coatings	■
Automotive and refinish coatings	■
Industrial coatings	■
Protective coatings	■

highly recommended ■
recommended □

Special Features

- Quick de-aeration and defoaming effect for pigmented solvent free epoxy flooring
- Does not interfere intercoat adhesion
- Improve leveling
- Heat stable

Application

Architectural coatings	□
Wood and furniture coatings	■
Automotive and refinish coatings	□
Can/coil coatings	□
Industrial coatings	■

highly recommended ■
recommended □

Product Specification

Density 20 °C	0.80 g/cm ³
Refractive index	1.414
Color	Max. 1
Appearance	Clear transparent liquid

Addition levels

- Based on total formulation: 0.1 – 0.6 %
Added before grinding.

Product Specification

Density 20°C	0.91 g/cm ³
Color	Max. 3
Appearance	Clear colorless liquid

Addition levels

- Based on total formulation: 0.1 – 1.0 %
Added in grinding stage or under high shear forces incorporation.

Packaging

- 20 kg
- 150 kg

Shelf life

UNIQ® FOAM 245 S should be stored in a cool dry place. When kept in an original unopened container, it will keep up to 5 years from the date of manufacture.

Packaging

- 22 kg
- 170 kg

Shelf life

UNIQ® FOAM 272 S should be stored in a cool dry place. When kept in an original unopened container, it will keep up to 5 years from the date of manufacture. At low temperature the product may become turbid, this will not affect the product performances.

UNIQ® FOAM 280 W

Water based silicone defoamer



UNIQ® FOAM

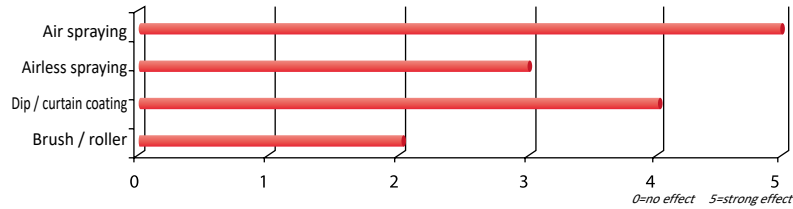

UNIQ® FOAM 280 W is a strong defoamer especially suitable for grinding pigment pastes. Very strong and effective in destroying the micro-foam as well the macro-foam what will result in an excellent grinding conditions to achieve more faster the particle size. It is long persistent and stable after storage. Low dosage is enough for the whole grinding process.

UNIQ® FOAM 295 W

Water based silicone defoamer

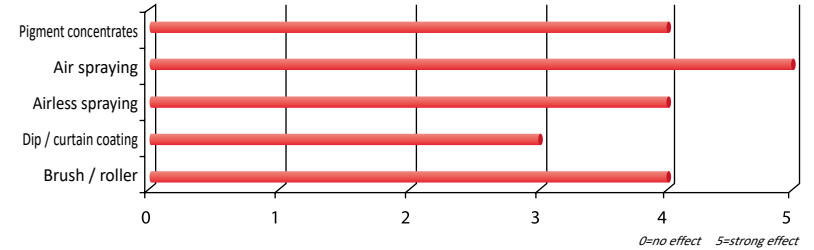

UNIQ® FOAM 295 W is a strong defoamer based on organic silicon, this product can be used for grinding and spraying conditions. Working well against micro-foam, therefore also well suited for self-leveling water based epoxy flooring systems and pigment concentrates.

Special Features

- Water based applications
- Strong defoamer for grinding conditions
- Long term persistent
- Silicone based
- Heat stable

Application

Architectural coatings	<input type="checkbox"/>
Wood and furniture coatings	<input checked="" type="checkbox"/>
Automotive and refinish coatings	<input checked="" type="checkbox"/>
Can/coil coatings	<input checked="" type="checkbox"/>
Industrial coatings	<input checked="" type="checkbox"/>

highly recommended
recommended

Special Features

- Water based applications
- Strong defoamer for grinding conditions
- Long term persistent
- Silicone based
- Heat stable

Application

Architectural coatings	<input checked="" type="checkbox"/>
Wood and furniture coatings	<input checked="" type="checkbox"/>
Automotive and refinish coatings	<input type="checkbox"/>
Can/coil coatings	<input type="checkbox"/>
Pigment concentrates	<input checked="" type="checkbox"/>

highly recommended
recommended

Product Specification

Density	1.01 g/cm ³
Appearance	Clear liquid

Addition levels

- Based on total formulation: 0.1 – 1.0 %

Product Specification

Density 20°C	1.01 g/cm ³
Refractive index	1.450
Color	Max. 1
Appearance	Slightly turbid liquid

Addition levels

- Based on total formulation: 0.1 – 1.0 %

Most of time 0.3 % is sufficient, but for airless application higher dosage might be required.

Packaging

- 25 kg
- 190 kg

Shelf life

UNIQ® FOAM 280 W should be stored in a cool dry place. When kept in an original unopened container, it will keep up to 2 years from the date of manufacture.

Packaging

- 25 kg
- 190 kg

Shelf life

UNIQ® FOAM 295 W should be stored in a cool dry place. When kept in an original unopened container, it will keep up to 5 years from the date of manufacture. At low temperature the product may become turbid, this will not affect the product performances.

UNIQ® FOAM LP2500

Water based silicone defoamer

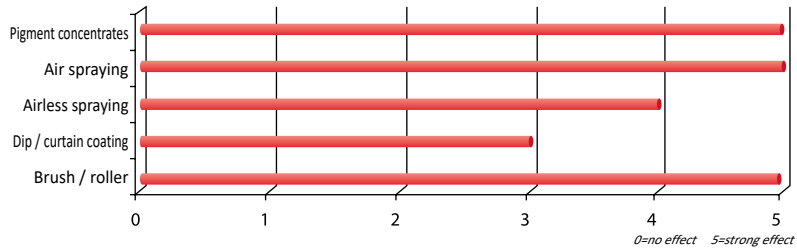

UNIQ®FOAM LP2500 is a strong defoamer based on organic silicon, this product can be used for grinding and spraying conditions. Working well against micro-foam, therefore also well suited for all water based systems and pigment paste.

UNIQ® FOAM LP2560

Water based silicone defoamer

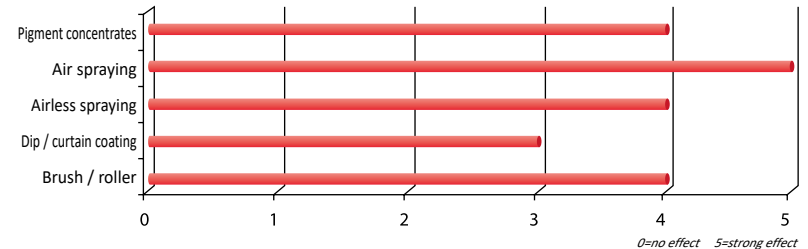

UNIQ®FOAM LP2560 is a strong defoamer based on organic silicon, this product can be used for grinding and spraying conditions. Working well against micro-foam, therefore also well suited for all water based systems.

Special Features

- Water based applications
- Strong defoamer for grinding conditions
- Long term persistent
- Silicone based
- Heat stable

Application

Architectural coatings	<input type="checkbox"/>
Wood and furniture coatings	<input checked="" type="checkbox"/>
Automotive and refinish coatings	<input type="checkbox"/>
Industrial coatings	<input type="checkbox"/>
Pigment concentrates	<input checked="" type="checkbox"/>

highly recommended ■
recommended □

Special Features

- Water based applications
- Strong defoamer for grinding conditions
- Long term persistent
- Silicone based
- Heat stable

Application

Architectural coatings	<input type="checkbox"/>
Wood and furniture coatings	<input checked="" type="checkbox"/>
Automotive and refinish coatings	<input type="checkbox"/>
Can/coil coatings	<input type="checkbox"/>
Industrial coatings	<input checked="" type="checkbox"/>

highly recommended ■
recommended □

Product Specification

Density 20 °C	0.97 g/cm ³
Appearance	slightly turbid liquid

Addition levels

- Based on total formulation: 0.1 – 1.0 %

Product Specification

Density 20°C	0.99 g/cm ³
Appearance	White liquid

Addition levels

- Based on total formulation: 0.1 – 1.0 %

Packaging

- 25 kg
- 200 kg

Shelf life

UNIQ®FOAM LP2500 should be stored in a cool dry place. When kept in an original unopened container, it will keep up to 2 years from the date of manufacture.

Packaging

- 25 kg
- 200 kg

Shelf life

UNIQ®FOAM LP2560 should be stored in a cool dry place. When kept in an original unopened container, it will keep up to 2 years from the date of manufacture.

UNIQ[®] FLOW



for coating industrie



UNIQ[®] FLOW 350 W

Polymeric Fluorocarbon compound leveling agent

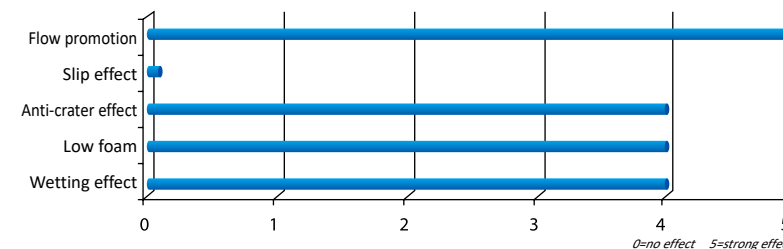

UNIQ[®] FLOW 350 W is a silicone free and can offer strong reduction of surface tension and improves wetting effect, gives strong anti-crater and is very low foaming. Meanwhile, it shows the good performance of fast wetting and leveling on difficult corners to achieve good film build up.

UNIQ[®] FLOW 350 W is based on a new chemistry technology developed by UNIQCHEM.

Special Features

- Suitable for water-, solvent-borne and solvent free applications including UV
- Excellent leveling, long wave-effect
- Silicone free anti-crater agent
- Excellent substrate wetting
- Good defoaming properties
- pH independent
- No intercoat adhesion problems
- Heat stable, suitable for high baking systems

Product Specification

Active ingredients	100 %
Density 20°C	1.12 g/cm ³
Color	Max. 10
Appearance	Slight turbid brownish liquid

Packaging

- 25 kg
- 210 kg

Application

Architectural coatings	■
Wood and furniture coatings	■
Automotive and refinish coatings	■
Can/coil coatings	■
Protective coatings	■
Industrial coatings	■

highly recommended ■
recommended □

Addition levels

- Based on total formulation: 0.1 – 1.0 %

UNIQ[®] FLOW 350 W is slight turbid, when mixed into the formulation it will become completely soluble and the turbidity will be disappear.

Shelf life

UNIQ[®] FLOW 350 W should be stored in a cool dry place. When kept in an original unopened container, it will keep up to 5 years from the date of manufacture.

UNIQ® FLOW 361 S

Polymeric Fluorocarbon compound leveling agent

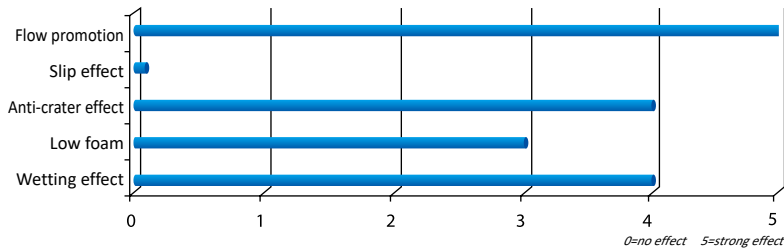

UNIQ®FLOW 361 S is a silicone free and can offer strong reduction of surface tension, improves wetting effect and has strong anti-crater performances. Meanwhile, it shows the good performance of fast wetting and leveling on difficult corners to achieve good film build up. The product is especially suitable for high performance coatings like automotive and refinish clear coatings.

UNIQ®FLOW 361 S the compatibility has been improved to give excellent clarity in all resins.

Special Features

- Solvent based applications
- Excellent leveling, long wave
- Anti-crater agent
- Excellent substrate wetting
- Silicone free
- Heat stable

Application

Architectural coatings	■
Wood and furniture coatings	■
Automotive and refinish coatings	■
Can/coil coatings	
Protective coatings	■
Industrial coatings	■

highly recommended ■
recommended □

Product Specification

Active ingredients	100 %
Density 20 °C	1.08 g/cm ³
Color	Max. 4
Appearance	Clear colorless liquid

Addition levels

- Based on total formulation: 0.05 – 0.5 %

Packaging

- 25 kg
- 200 kg

Shelf life

UNIQ®FLOW 361 S should be stored in a cool dry place. When kept in an original unopened container, it will keep up to 5 years from the date of manufacture.

UNIQ® FLOW 372 S

Fluorocarbon modified polyacrylate leveling agent for solvent and water based system

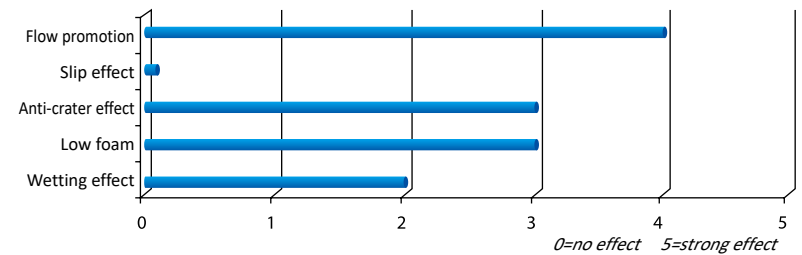

UNIQ®FLOW 372 S is a silicone free fluor modified acrylic leveling agent to be used in solvent- and water-based coating systems. Especially in water based systems the product shows good defoaming performances. For water based systems it is advisable to adjust the pH to 8 – 8.5 to make the product fully water soluble.

Special Features

- Solvent and water based applications
- Excellent leveling, long wave-effect
- Prevents crater
- Helps substrate wetting
- Act as a defoamer and de-aeration aid
- Suitable for high gloss coating
- Heat stable

Application

Architectural coatings	■
Wood and furniture coatings	■
Automotive and refinish coatings	■
Can/coil coatings	■
Protective coatings	■
Industrial coatings	■

highly recommended ■
recommended □

Product Specification

Active ingredients	60 %
Density 20 °C	0.96 g/cm ³
Solvent	Sec. butanol
Color	Max. 1
Appearance	Clear colorless liquid

Addition levels

- Based on total formulation: 0.1 – 1.0 %

Packaging

- 25 kg
- 190 kg

Shelf life

UNIQ®FLOW 372 S should be stored in a cool dry place. When kept in an original unopened container, it will keep up to 5 years from the date of manufacture.

UNIQ® FLOW 375 S

Fluorocarbon modified polyacrylate leveling agent for solvent based system

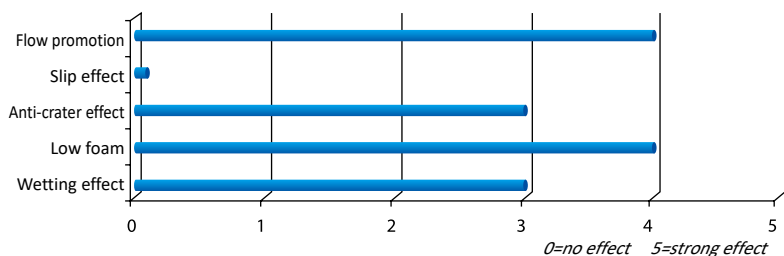

UNIQ®FLOW 375 S is a fluor modified acrylic leveling agent to be used in solvent based coating systems showing some defoaming performances. Due to the composition the compatibility needs to be checked for haze. For improved compatibility UNIQ®FLOW 376 S is recommended.

UNIQ® FLOW 376 S

Fluorocarbon modified polyacrylate leveling agent for solvent based system

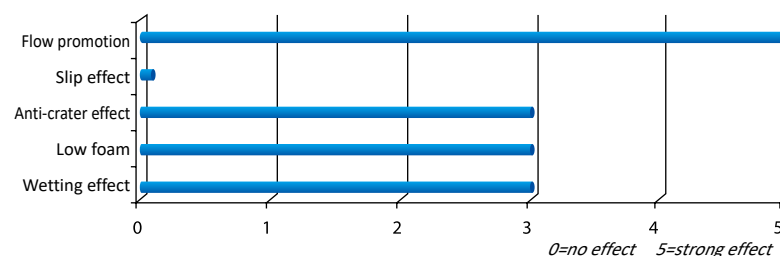

UNIQ®FLOW 376 S is a fluor modified acrylic leveling agent to be used in solvent based coating systems showing excellent compatibility with most of the resins. Can be used also in UPE primers for wood coatings remaining excellent clarity. Gives very fast leveling and with perfect appearances for clear coats.

UNIQ®FLOW

Special Features

- Solvent borne applications
- Excellent leveling, long wave-effect
- Prevents cratering
- Helps substrate wetting
- Acts as a defoamer and de-aeration aid
- Does not interfere intercoat adhesion
- Silicone-free
- Heat stable

Application

Architectural coatings	■
Wood and furniture coatings	■
Automotive and refinish coatings	■
Can/coil coatings	■
Protective coatings	■
Industrial coatings	■

highly recommended ■
recommended □

Special Features

- Suitable for high gloss clear coating
- Excellent leveling, long wave-effect
- Prevents cratering
- Helps substrate wetting
- Acts as a defoamer and de-aeration aid
- Silicone-free
- Heat stable

Application

Architectural coatings	■
Wood and furniture coatings	■
Automotive and refinish coatings	■
Can/coil coatings	□
Protective coatings	■
Industrial coatings	■

highly recommended ■
recommended □

Product Specification

Active ingredients	70 %
Density 20°C	0.99 g/cm ³
Solvent	Xylene
Color	Max. 1
Appearance	Clear colorless liquid

Addition levels

- Based on total formulation: 0.1 – 1.0 %

Product Specification

Active ingredients	70 %
Density 20 °C	1.02 g/cm ³
Solvent	PMA
Color	Max. 1
Appearance	Clear colorless liquid

Addition levels

- Based on total formulation: 0.1 – 1.0 %

Packaging

- 25 kg
- 190 kg

Shelf life

UNIQ®FLOW 375 S should be stored in a cool dry place. When kept in an original unopened container, it will keep up to 5 years from the date of manufacture.

Packaging

- 25 kg
- 190 kg

Shelf life

UNIQ®FLOW 376 S should be stored in a cool dry place. When kept in an original unopened container, it will keep up to 5 years from the date of manufacture.

UNIQ® FLOW 380 S

Polyacrylate based surface additive with air-release properties

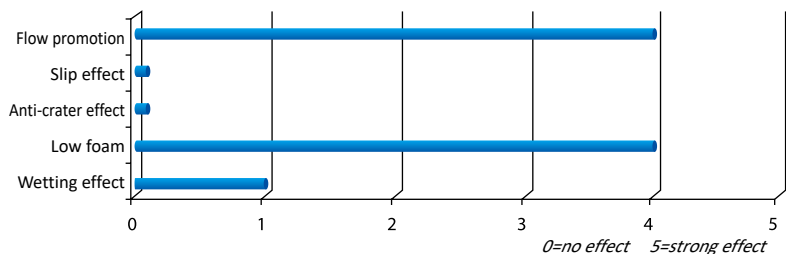

UNIQ®FLOW 380 S is a cost effective acrylic leveling agent for solvent based coating systems showing good defoaming performances.

UNIQ® FLOW 384 S

Polyacrylate based surface additive with air-release properties

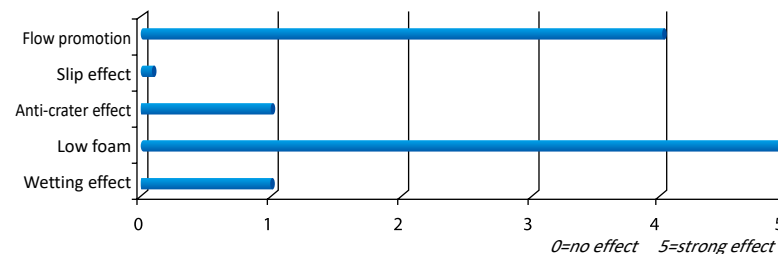

UNIQ®FLOW 384 S is a cost effective acrylic leveling agent for solvent based and solvent free coating systems showing excellent defoaming and leveling performances. It is non-silicone and therefore will not cause intercoat adhesion problems. It is heat stable and therefore suitable for the baking system. The compatibility needs to be checked, especially in clear coats.

UNIQ®FLOW

Special Features

- Solvent borne applications
- Improve levelling
- Acts as a defoamer and de-aeration aid
- Does not interfere intercoat adhesion
- Silicone free
- Heat stable

Application

Architectural coatings	■
Wood and furniture coatings	■
Automotive and refinish coatings	■
Can/coil coatings	■
Protective coatings	■
Industrial coatings	■

highly recommended ■
recommended □

Special Features

- Solvent borne and solvent free applications
- Improves levelling
- Acts as a defoamer and de-aeration aid
- Does not interfere intercoat adhesion
- Silicone free
- Heat stable

Application

Architectural coatings	
Wood and furniture coatings	■
Automotive and refinish coatings	■
Can/coil coatings	■
Protective coatings	■
Industrial coatings	■

highly recommended ■
recommended □

Product Specification

Active ingredients	100 %
Density 20 °C	1.0 g/cm ³
Color	Max. 1
Appearance	Clear colorless liquid

Addition levels

- Based on total formulation: 0.1 – 1.0 %

Product Specification

Active ingredients	100 %
Density	1.00 g/cm ³
Color	Max. 1
Appearance	Transparent liquid

Addition levels

- Based on total formulation: 0.1 – 1.0 %

Check compatibility especially in clear coats.

Packaging

- 25 kg
- 190 kg

Shelf life

UNIQ®FLOW 380 S should be stored in a cool dry place. When kept in an original unopened container, it will keep up to 5 years from the date of manufacture.

Packaging

- 25 kg
- 190 kg

Shelf life

UNIQ®FLOW 384 S should be stored in a cool dry place. When kept in an original unopened container, it will keep up to 5 years from the date of manufacture.

UNIQ® FLOW 386 S

Polyacrylate based leveling agent for solvent based applications

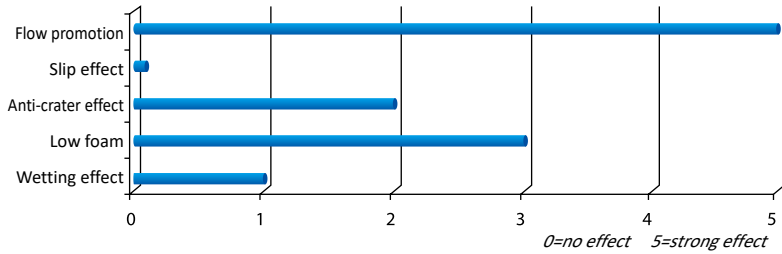

UNIQ®FLOW 386 S is a cost effective acrylic leveling agent for solvent based coating systems showing excellent compatibility and good long wave leveling performances. In addition it increases the gloss.

UNIQ® FLOW 392 S

Acrylate leveling agent with anti-popping properties

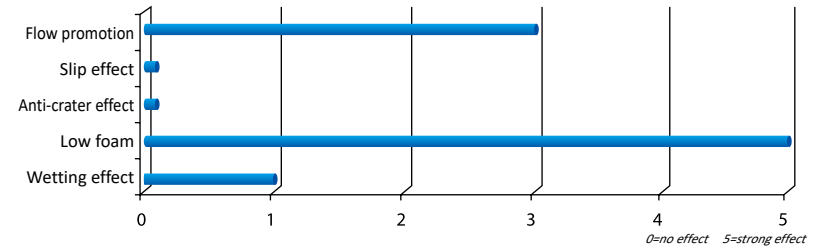

UNIQ®FLOW 392 S is a polyacrylate surface active agent for solvent based applications especially suitable for baking systems. It promotes leveling, has defoaming effect (particularly for microfoam), and is effective for very short baking times. Suitable for roller application, conventional spraying application, and airless/airmix applications.

Special Features

- Solvent based applications
- Improves leveling
- Excellent compatibility,
- Suitable for high gloss (clear) coating
- Does not interfere intercoat adhesion
- Silicone free

Application

Architectural coatings	■
Wood and furniture coatings	■
Automotive and refinish coatings	■
Can/coil coatings	■
Protective coatings	■
Industrial coatings	■

highly recommended ■
recommended □

Special Features

- Anti-popping in solvent borne baking applications
- Improve leveling
- Excellent defoaming and degassing properties
- Does not interfere intercoat adhesion
- Silicone free
- Suitable for roller-, spraying- and airless/airmix applications

Application

Architectural coatings	■
Wood and furniture coatings	■
Automotive and refinish coatings	■
Can/coil coatings	■
Protective coatings	■
Industrial coatings	■

highly recommended ■
recommended □

Product Specification

Active ingredients	52 %
Solvent	PMA
Density 20 °C	1.0 g/cm ³
Color	Max. 1
Appearance	Clear colorless liquid

Addition levels

- Based on total formulation: 0.1 – 1.0 %

Product Specification

Active ingredients	50 %
Solvent	PMA
Density 20 °C	1.0 g/cm ³
Color	Max. 1
Appearance	Clear colorless liquid

Addition levels

- Based on total formulation: 0.1 – 1.0 %

Packaging

- 25 kg
- 180 kg

Shelf life

UNIQ®FLOW 386 S should be stored in a cool dry place. When kept in an original unopened container, it will keep up to 5 years from the date of manufacture.

Packaging

- 25 kg
- 190 kg

Shelf life

UNIQ®FLOW 392 S should be stored in a cool dry place. When kept in an original unopened container, it will keep up to 5 years from the date of manufacture.

UNIQ® FLOW 400 U

Organically modified polysiloxane

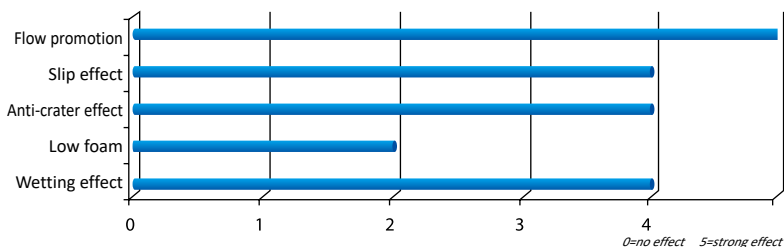

UNIQ® FLOW 400 U is silicone surface additive for solvent- and water based coating systems with a medium reduction of surface tension and a medium increase of surface slip.

UNIQ® FLOW 400 U increases slip and improves leveling, gloss and prevent the formation of Bénard cells. It also improves substrate wetting and anti-blocking properties.

Special Features

- Suitable for solvent and water borne
- Improve slip and hand feeling
- Improve substrate wetting
- Low foam
- improves scratch resistance
- minimal influence on intercoat adhesion

Application

Architectural coatings	■
Wood and furniture coatings	■
Automotive and refinish coatings	■
Can/coil coatings	
Protective coatings	■
Industrial coatings	■

highly recommended ■
recommended □

Product Specification

Active ingredients	50 %
Density 20°C	0.91 g/cm ³
Solvent	Iso-Butanol
Color	Max. 1
Appearance	Clear colorless liquid

Addition levels

- Based on total formulation: 0.1 – 1.0 %

Packaging

- 25 kg
- 180 kg

Shelf life

UNIQ® FLOW 400 U should be stored in a cool dry place. When kept in an original unopened container, it will keep up to 2 years from the date of manufacture. At low temperature the product may become turbid, this will not affect the product performances.

UNIQ® FLOW 415 S

Organically modified polysiloxane

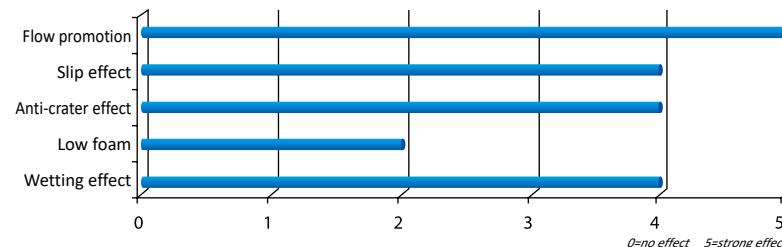

UNIQ® FLOW 415 S is a highly effective silicone additive, provides a strong reduction of surface tension. Offers good wetting of critical substrates. In pigmented systems it can prevent the formation of Bénard cells and improve leveling. **UNIQ® FLOW 415 S** improves the acceptance of dust and spray mist and increases surface slip. It reduces air draft sensitivity in wood and furniture coatings.

Special Features

- Good substrate wetting
- Improve slip and hand feeling
- Low foaming
- Excellent clarity in clear coatings
- Good recoatability
- Improves scratch resistance
- Improves mar resistance

Application

Architectural coatings	■
Wood and furniture coatings	■
Automotive and refinish coatings	■
Can/coil coatings	
Protective coatings	■
Industrial coatings	■

highly recommended ■
recommended □

Product Specification

Active ingredients	15 %
Density 20°C	0.90 g/cm ³
Solvent	Butyl acetate
Color	Max. 1
Appearance	Clear colorless liquid

Addition levels

- Based on total formulation: 0.1 – 1.0 %

Packaging

- 25 kg
- 180 kg

Shelf life

UNIQ® FLOW 415 S should be stored in a cool dry place. When kept in an original unopened container, it will keep up to 5 years from the date of manufacture.

UNIQ® FLOW 430 S

Organically modified polysiloxane

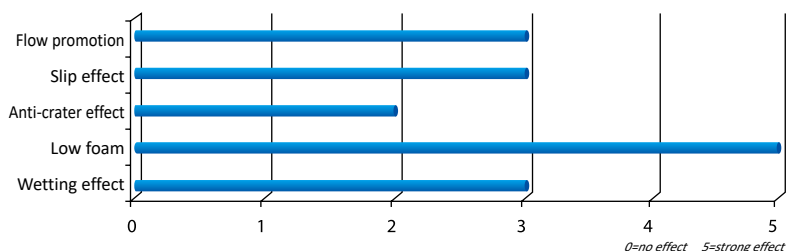

UNIQ® FLOW 430 S is allyl/alkyl modified polysiloxane leveling agents with some strong defoaming performances, particularly for non-polar to medium polar systems. It helps to prevent problems with ghosting and telegraphing when it is used in the layer that will be recoated. UNIQ® FLOW 430 S also helps to improve the matting agent orientation at the surface to avoid clouding.

Special Features

- Excellent defoaming effect, especially against micro foam
- Suitable for baking system
- Minimal influence on intercoat adhesion
- Less suited for high gloss clear coatings
- Improves matting agents orientation

Application

Architectural coatings	■
Wood and furniture coatings	■
Automotive and refinish coatings	■
Can/coil coatings	□
Protective coatings	■
Industrial coatings	■

highly recommended ■
recommended □

Product Specification

Active ingredients	100 %
Density 20 °C	0.97 g/cm ³
Color	Max. 2
Appearance	Yellowish liquid

Addition levels

- Based on total formulation: 0.1 – 1.0 %

Packaging

- 25 kg
- 190 kg

Shelf life

UNIQ® FLOW 430 S should be stored in a cool dry place. When kept in an original unopened container, it will keep up to 2 years from the date of manufacture.

UNIQ® FLOW 437 S

Blend of high-boiling aromatic, ketone and ester solvents, including a highly compatible polysiloxane

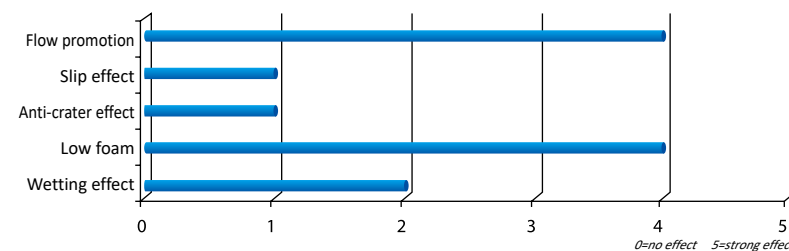

UNIQ® FLOW 437 S prevents surface irregularities like craters, scars, blisters, pinholes and orange peel. It suppresses the risk of solvent popping and improves leveling. It is recommended for use in solvent-borne, air-drying coatings and baking systems.

Special Features

- Excellent compatibility
- Prevents surface defects like cratering, scarring or blistering in air drying and stoving paints
- Prevents streaking during painting and spraying of chlorinated rubber and coatings based on other chlorinated polymers
- Prevents popping in stoving enamels
- Improve leveling
- no recoat problem

Application

Architectural coatings	■
Wood and furniture coatings	■
Automotive and refinish coatings	■
Can/coil coatings	□
Protective coatings	■
Industrial coatings	■

highly recommended ■
recommended □

Product Specification

Solvent	Hydrocarbon C9 aromatics/DIBK
Density 20 °C	0.86 g/cm ³
Flash point	42°C
Appearance	Clear colorless liquid

Addition levels

- Based on total formulation: 1.0 – 5.0 %

Packaging

- 25 kg
- 170 kg

Shelf life

UNIQ® FLOW 437 S should be stored in a cool dry place. When kept in an original unopened container, it will keep up to 5 years from the date of manufacture.

UNIQ® FLOW 440 U

Organically modified polysiloxane

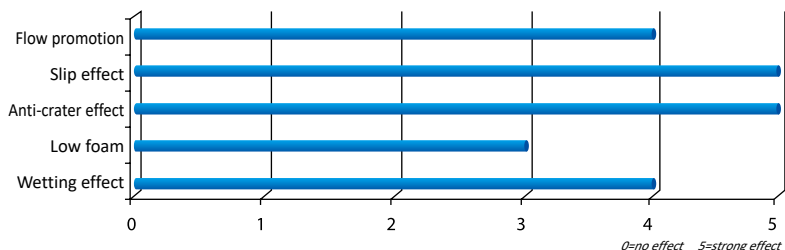

UNIQ® FLOW 440 U is modified polyether polysiloxane leveling agents. The product can offer strong reduction of surface tension and improves wetting effect and anti-crater effect of substrate. Meanwhile, it shows the good performance of fast leveling.

UNIQ® FLOW 470 U

Organically modified polysiloxane

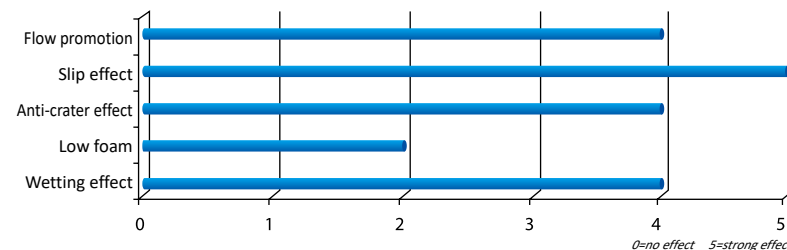

UNIQ® FLOW 470 U is modified polyether polysiloxane leveling and wetting agent. It is particularly recommended for radiation-curable coatings. It improves the substrate wetting and the leveling. UNIQ® FLOW 470 U is particularly suitable for high-speed machines with low stabilization. Its good compatibility with standard binders enables highly transparent coatings to be produced.

UNIQ® FLOW

Special Features

- Suitable for solvent and water borne
- Anti-crater agent
- Good substrate wetting
- Low foam
- Improve anti floating and flooding
- minimal influence on intercoat adhesion

Application

Architectural coatings	■
Wood and furniture coatings	■
Automotive and refinish coatings	■
Can/coil coatings	
Protective coatings	■
Industrial coatings	■

highly recommended ■
recommended □

Special Features

- Used in waterborne, radiation-curing and solventborne and solvent free formulations
- Good substrate wetting
- Improve slip hand feeling
- Low foaming
- Good clarity
- Good recoatability
- Improves scratch resistance

Application

Architectural coatings	■
Wood and furniture coatings	■
Automotive and refinish coatings	■
Can/coil coatings	
Protective coatings	■
Industrial coatings	■

highly recommended ■
recommended □

Product Specification

Active ingredients	50 %
Density 20 °C	0.98 g/cm ³
Solvent	Iso-Butanol
Appearance	Clear colorless liquid

Addition levels

- Based on total formulation: 0.1 – 0.3 %

Product Specification

Active ingredients	100 %
Density 20°C	1.02 g/cm ³
Color	Max. 1
Appearance	Clear colorless liquid

Addition levels

- Based on total formulation: 0.1 – 1.0 %

Packaging

- 25 kg
- 190 kg

Shelf life

UNIQ® FLOW 440 U should be stored in a cool dry place. When kept in an original unopened container, it will keep up to 2 years from the date of manufacture.

Packaging

- 25 kg
- 190 kg

Shelf life

UNIQ® FLOW 470 U should be stored in a cool dry place. When kept in an original unopened container, it will keep up to 3 years from the date of manufacture. At low temperature the product may become turbid, this will not affect the product performances.

UNIQ® FLOW 477 U

Organically modified polysiloxane

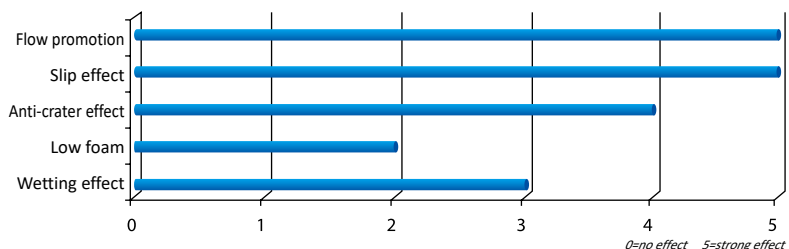

UNIQ®FLOW 477 U is modified polyether polysiloxane leveling agents. The product can offer strong reduction of surface tension and improves wetting effect and anti-crater effect of substrate. Meanwhile, it shows the good performance of fast leveling with excellent hand feeling and slip effect.

UNIQ® FLOW 487 U

Organically modified polysiloxane

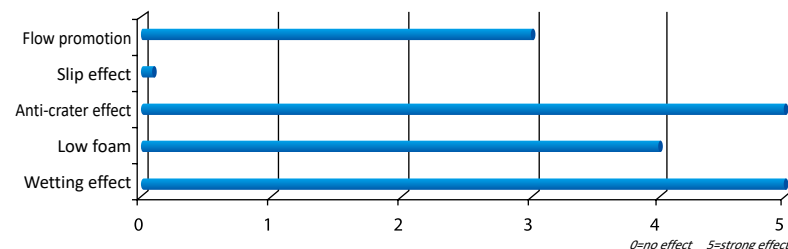

UNIQ®FLOW 487 U can be used in various water- solvent- borne and UV coatings to improve substrate wetting effect. The product can be used from primer to topcoat without effecting the intercoat adhesion. In water-borne coatings it can be used in pH range from 4.0 – 9.0 and it is low foaming. Although the product is silicone based, it will not give slip and will not improve scratch resistance.

UNIQ®FLOW

Special Features

- Used in waterborne, radiation-curing and solventborne and solvent free formulations
- Good substrate wetting
- Improve slip hand feeling
- Low foaming
- Good clarity
- Good recoatability
- Improves scratch resistance

Application

Architectural coatings	■
Wood and furniture coatings	■
Automotive and refinish coatings	■
Can/coil coatings	
Protective coatings	■
Industrial coatings	■

highly recommended ■
recommended □

Special Features

- Excellent anti crater
- Excellent substrate wetting
- Excellent compatibility with water
- No influence on intercoat adhesion
- Low foam stabilization
- pH independent

Application

Architectural coatings	■
Wood and furniture coatings	■
Automotive and refinish coatings	■
Can/coil coatings	□
Protective coatings	■
Industrial coatings	■

highly recommended ■
recommended □

Product Specification

Active ingredients	100 %
Density 20°C	1.04 g/cm ³
Color	Max. 2
Appearance	Clear liquid

Addition levels

- Based on total formulation: 0.1 – 1.0 %

Product Specification

Active ingredients	100 %
Density 20°C	1.02 g/cm ³
Color	Max. 2
Appearance	Clear liquid

Addition levels

- Based on total formulation: 0.1 – 1.0 %

Packaging

- 25 kg
- 190 kg

Shelf life

UNIQ®FLOW 477 U should be stored in a cool dry place. When kept in an original unopened container, it will keep up to 3 years from the date of manufacture. At low temperature the product may become turbid, this will not affect the product performances.

Packaging

- 25 kg
- 190 kg

Shelf life

UNIQ®FLOW 487 U should be stored in a cool dry place. When kept in an original unopened container, it will keep up to 3 years from the date of manufacture. At low temperature the product may become turbid, this will not affect the product performances.

UNIQ® FLOW 488 U

Organically modified polysiloxane

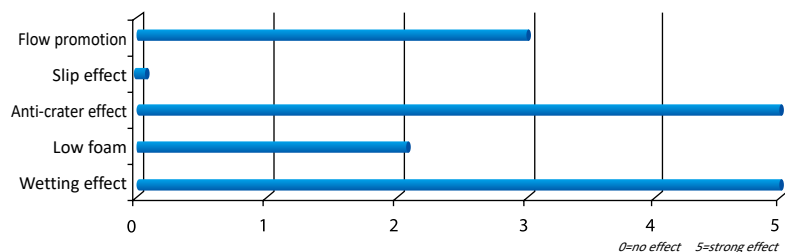

UNIQ®FLOW 488 U can be used in various water- solvent- borne and UV coatings to improve substrate wetting effect. The product can be used from primer to topcoat without effecting the intercoat adhesion. In water-borne coatings it can be used in pH range from 4.0 – 9.0. It gives the best surface tension reduction properties. Although the product is silicone based, it will not give slip and will not improve scratch resistance.

UNIQ® FLOW 491 U

Organically modified polyether polysiloxane with strong reduction of surface tension

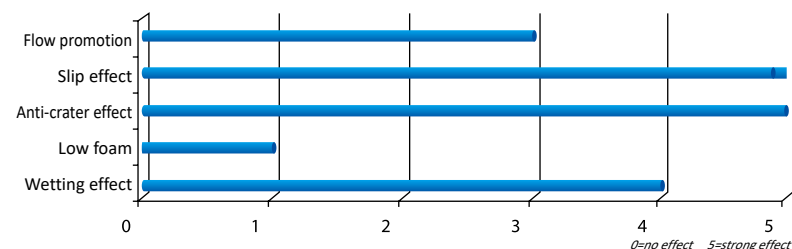

UNIQ®FLOW 491 U is modified polyether polysiloxane leveling agents. The additive gives strong surface tension reduction properties in coatings. The substrate wetting is improved and therefore can also act as an anti-crater agent. **UNIQ®FLOW 491 U** gives strong surface slip and can help to increase the gloss. In aqueous systems it improves the anti-blocking properties.

UNIQ®FLOW

Special Features

- Excellent anti crater
- Excellent substrate wetting
- Excellent compatibility with water
- No influence on intercoat adhesion
- pH independent

Application

Architectural coatings	■
Wood and furniture coatings	■
Automotive and refinish coatings	■
Can/coil coatings	□
Protective coatings	■
Industrial coatings	■

highly recommended ■
recommended □

Special Features

- Used in waterborne, radiation-curing and solventborne and solvent free formulations
- Outstanding substrate wetting
- Improve slip hand feeling
- Excellent clarity in clear coats
- Good recoatability
- Improves scratch resistance

Application

Architectural coatings	■
Wood and furniture coatings	■
Automotive and refinish coatings	■
Can/coil coatings	
Protective coatings	■
Industrial coatings	■

highly recommended ■
recommended □

Product Specification

Active ingredients	100 %
Density 20°C	1.02 g/cm ³
Color	Max. 3
Appearance	Clear liquid

Addition levels

- Based on total formulation: 0.1 – 1.0 %

Product Specification

Active ingredients	100 %
Density 20°C	1.02 g/cm ³
Color	Max. 1
Appearance	Clear colorless liquid

Addition levels

- Based on total formulation: 0.1 – 1.0 %

Packaging

- 25 kg
- 180 kg

Shelf life

UNIQ®FLOW 488 U should be stored in a cool dry place. When kept in an original unopened container, it will keep up to 3 years from the date of manufacture. At low temperature the product may become turbid, this will not affect the product performances.

Packaging

- 25 kg
- 190 kg

Shelf life

UNIQ®FLOW 491 U should be stored in a cool dry place. When kept in an original unopened container, it will keep up to 3 years from the date of manufacture. At low temperature the product may become turbid, this will not affect the product performances.

UNIQ® FLOW 493 U

Organically modified polyether polysiloxane with strong reduction of surface tension

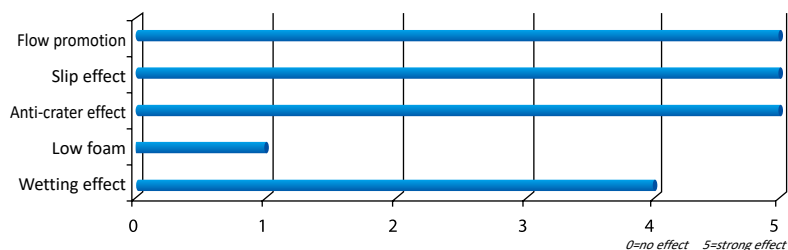

UNIQ® FLOW 493 U is modified polyether polysiloxane leveling agents. The additive gives strong surface tension reduction properties in coatings. The substrate wetting is improved and therefore can also act as an anti-crater agent. **UNIQ® FLOW 493 U** gives strong surface slip and can help to increase the gloss. In aqueous systems it improves the anti-blocking properties.

Special Features

- Used in waterborne, radiation-curing and solventborne and solvent free formulations
- Outstanding substrate wetting
- Improve slip hand feeling
- Excellent clarity in clear coats
- Good recoatability
- Improves scratch resistance

Application

Architectural coatings	■
Wood and furniture coatings	■
Automotive and refinish coatings	■
Can/coil coatings	
Protective coatings	■
Industrial coatings	■

highly recommended ■
recommended □

Product Specification

Active ingredients	100 %
Density 20°C	1.04 g/cm ³
Color	Max. 3
Appearance	Clear liquid

Addition levels

- Based on total formulation: 0.1 – 1.0 %

Packaging

- 25 kg
- 190 kg

Shelf life

UNIQ® FLOW 493 U should be stored in a cool dry place. When kept in an original unopened container, it will keep up to 3 years from the date of manufacture. At low temperature the product may become turbid, this will not affect the product performances.

UNIQ® FLOW 495 U

Organically modified polyether polysiloxane with strong reduction of surface tension

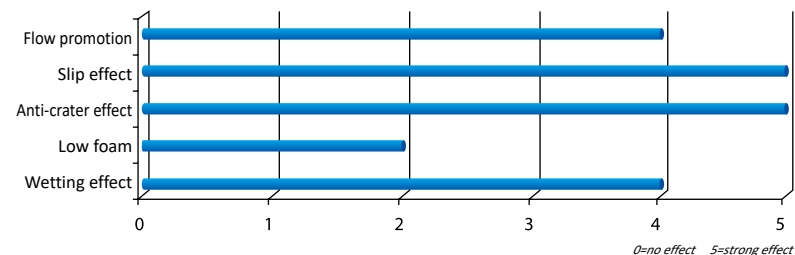

UNIQ® FLOW 495 U is modified polyether polysiloxane leveling agents. The additive gives strong surface tension reduction properties in coatings. The substrate wetting is improved and therefore can also act as an anti-crater agent. **UNIQ® FLOW 495 U** gives strong surface slip and can help to increase the gloss. In wood coating the product will give excellent hand-feeling. In aqueous systems it improves the anti-blocking properties.

Special Features

- Used in waterborne, radiation-curing and solventborne and solvent free formulations
- Outstanding substrate wetting
- Improve slip
- Excellent hand feeling
- Excellent clarity in clear coats
- Good recoatability
- Improves scratch resistance

Application

Architectural coatings	■
Wood and furniture coatings	■
Automotive and refinish coatings	■
Can/coil coatings	
Protective coatings	■
Industrial coatings	■

highly recommended ■
recommended □

Product Specification

Active ingredients	100 %
Density 20°C	1.04 g/cm ³
Color	Max. 1
Appearance	Clear colorless liquid

Addition levels

- Based on total formulation: 0.1 – 1.0 %

Packaging

- 25 kg
- 190 kg

Shelf life

UNIQ® FLOW 495 U should be stored in a cool dry place. When kept in an original unopened container, it will keep up to 3 years from the date of manufacture. At low temperature the product may become turbid, this will not affect the product performances.



UNIQ[®] SPERSE



UNIQ[®] SPERSE 510 S

Polyurethane dispersant for solvent system

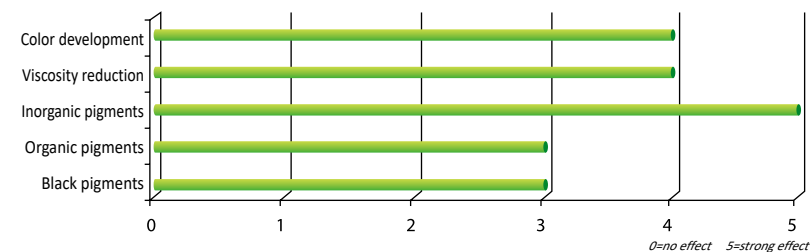

UNIQ[®] SPERSE 510 S is a wetting and dispersing additive for solvent based coating systems. The dispersant is especially suitable for inorganic pigments, extender pigments and matting agents. For matting agents and TiO₂ it will help to avoid hard sediments. In addition the matting agent orientation will be improved what will help to achieve faster your gloss level. UNIQ[®] SPERSE 510 S is also well suited for co-grinding process.

Special Features

- Solvent based applications
- Help orientation of matting agents
- Protects formation of hard sedimentation
- Also suited for extender pigments
- Excellent for co-grinding
- Prevents flooding and floating
- Improves hiding power

Application

Architectural coatings	■
Wood and furniture coatings	■
Automotive and refinish coatings	□
Industrial Coatings	■
Protective coatings	■

highly recommended ■
recommended □

Product Specification

Active ingredients	50.0 %
Solvent	PMA/Hydrocarbons C9 aromatics/Butylacetate
Density 20°C	0.98 g/cm ³
Acid value	14.0 mg KOH/g
Amine value	6.0 mg KOH/g
Color	Max.6
Appearance	Slight yellowish clear liquid

Addition levels

Amount of solid additive based on pigment (SOP):

- Inorganic pigments: 2–5 %
- Titanium dioxides: 1–3 %
- Organic pigments: 20–40 %
- Carbon blacks: 15–40 %
- Matting agents 5–10 %

The above recommended levels can be used for orientation and needs to be optimized by testing.

Packaging

- 25 kg
- 190 kg

Shelf life

UNIQ[®] SPERSE 510 S should be stored in a cool dry place. When kept in an original unopened container, it will keep up to 5 years from the date of manufacture.

UNIQ® SPERSE 550 S

Polyurethane dispersant for solvent system

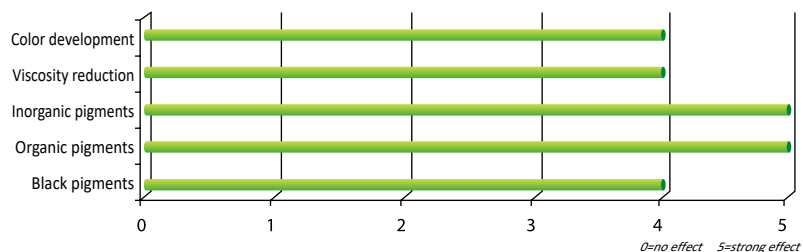

UNIQ® SPERSE 550 S is a wetting and dispersing additive for solvent based coating systems suited for the stabilization of inorganic, organic and carbon black pigments. It will help to reduce the viscosity and avoid flooding and floating. Suited for preparation of resin minimal pigment concentrates.

UNIQ® SPERSE 560 S

Polyurethane dispersant for solvent system

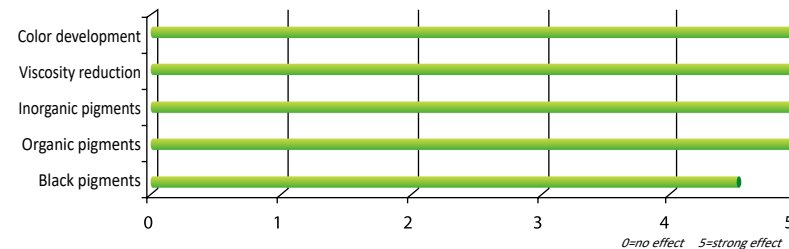

UNIQ® SPERSE 560 S is a wetting and dispersing additive for solvent based automotive and industrial coatings and pigment concentrates. Especially in two-pack PU and baking systems with excellent reduction of millbase viscosity. Also very well compatible with CAB and therefore well suited for basecoat. Gives excellent transparency with difficult pigments.

UNIQ® SPERSE

Special Features

- Solvent based applications
- Prevents flooding and floating
- Organic and Inorganic pigment
- Improves gloss and DOI
- Good viscosity reduction

Application

Architectural coatings	■
Wood and furniture coatings	■
Automotive and refinish coatings	□
Industrial coatings	■
Pigment concentrates	■
Protective coatings	■

highly recommended ■
recommended □

Special Features

- Solvent based applications
- Prevents flooding and floating
- Organic and Inorganic pigment
- Improves gloss and DOI
- Good viscosity reduction

Application

Architectural coatings	
Wood and furniture coatings	■
Automotive and refinish coatings	■
Industrial Coatings	■
Protective coatings	■

highly recommended ■
recommended □

Product Specification

Active ingredients	45.0 %
Solvent	butylacetate/PMA
Density 20°C	1.0 g/cm ³
Amine value	14.0 mg KOH/g
Color	Max.10
Appearance	Light brownish clear liquid

Addition levels

- Amount of solid additive based on pigment (SOP):
- Inorganic pigments: 2 – 5 %
 - Titanium dioxides: 1 – 3 %
 - Organic pigments: 15 – 30 %
 - Carbon blacks: 20 – 40 %

The above recommended levels can be used for orientation and needs to be optimized by testing.

Product Specification

Active ingredients	30.0 %
Solvent	n-BA/PMA/xylene
Density 20°C	0.95 g/cm ³
Amine value	8.0 mg KOH/g
Color	Max. 6
Appearance	Yellowish clear liquid

Addition levels

- Amount of solid additive based on pigment (SOP):
- Inorganic pigments: 2 – 5 %
 - Titanium dioxides: 1 – 3 %
 - Organic pigments: 15 – 40 %
 - Carbon blacks: 20 – 60 %

The above recommended levels can be used for orientation and needs to be optimized by testing.

Packaging

- 25 kg
- 190 kg

Shelf life

UNIQ® SPERSE 550 S should be stored in a cool dry place. When kept in an original unopened container, it will keep up to 5 years from the date of manufacture.

Packaging

- 25 kg
- 190 kg

Shelf life

UNIQ® SPERSE 560 S should be stored in a cool dry place. When kept in an original unopened container, it will keep up to 5 years from the date of manufacture. At low temperature the product may become turbid, this will not affect the product performances.

UNIQ® SPERSE 568 S

Structured Polymer

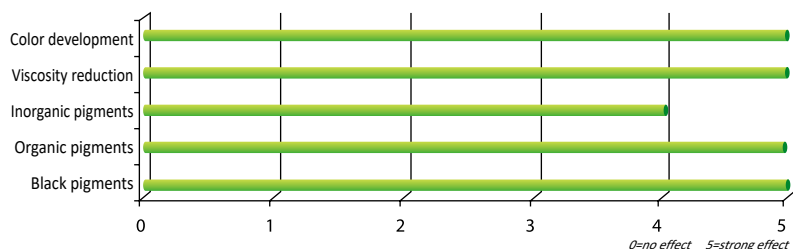

UNIQ® SPERSE 568 S is a wetting and dispersing additive for solvent based applications. The dispersant is especially developed for the grinding of carbon black to give excellent jetness with blue undertone. Also suitable for dispersing inorganic and organic pigments.

UNIQ® SPERSE 580 U

Structured Polymer

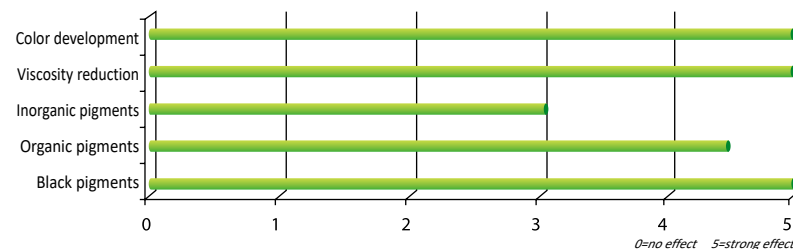

UNIQ® SPERSE 580 U is a wetting and dispersing additive for water based and solvent free applications. Suitable for industrial, automotive coating and resin free pigment concentrates. **UNIQ® SPERSE 580 U** is especially developed for the grinding of high channel black pigment, shows best jetness with blue undertone, and excellent dispersion stability and viscosity reduction. Also suitable for dispersing some organic pigments, shows excellent transparency and color development.

UNIQ® SPERSE

Special Features

- Solvent based applications
- Excellent dispersant for high channel black pigment, excellent jetness with blue undertone
- Strong viscosity reduction
- Excellent jetness and blue undertone
- Improves color development and Chroma

Application

Architectural coatings	<input type="checkbox"/>
Wood and furniture coatings	<input type="checkbox"/>
Automotive and refinish coatings	<input checked="" type="checkbox"/>
Can/coil coatings	<input checked="" type="checkbox"/>
Industrial coatings	<input checked="" type="checkbox"/>
Pigment concentrates	<input checked="" type="checkbox"/>
Protective coatings	<input checked="" type="checkbox"/>

highly recommended ■
recommended □

Product Specification

Active ingredients	50 %
Solvent	PMA
Density 20°C	1.02 g/cm ³
Amine value	30.0 mg KOH/g
Acid value	15.0 mg KOH/g
Color	Max. 7
Appearance	Brownish liquid

Addition levels

- Amount of solid additive based on pigment (SOP):
- Inorganic pigments: 2 – 5 %
 - Titanium dioxides: 2 – 5 %
 - Organic pigments: 15 – 40 %
 - Carbon blacks: 20 – 80 %

The above recommended levels can be used for orientation and needs to be optimized by testing.

Packaging

- 25 kg
- 200 kg

Shelf life

UNIQ® SPERSE 568 S should be stored in a cool dry place. When kept in an original unopened container, it will keep up to 5 years from the date of manufacture.

Special Features

- Water-borne and solvent free applications
- Excellent dispersant for high channel black pigment
- Suited for resin free pigment concentrates
- Strong viscosity reduction
- Excellent jetness and blue undertone
- Improves color development and Chroma

Application

Architectural coatings	<input type="checkbox"/>
Wood and furniture coatings	<input type="checkbox"/>
Automotive and refinish coatings	<input checked="" type="checkbox"/>
Can/coil coatings	<input checked="" type="checkbox"/>
Industrial coatings	<input checked="" type="checkbox"/>
Pigment concentrates	<input checked="" type="checkbox"/>
Protective coatings	<input type="checkbox"/>

highly recommended ■
recommended □

Product Specification

Active ingredients	100 %
Density 20°C	1.07 g/cm ³
Amine value	52.0 mg KOH/g
Appearance	Brownish clear liquid

Addition levels

- Amount of solid additive based on pigment (SOP):
- Inorganic pigments: 2 – 12 %
 - Titanium dioxides: 1 – 4 %
 - Organic pigments: 15 – 50 %
 - Carbon blacks: 20 – 100 %

The above recommended levels can be used for orientation and needs to be optimized by testing.

Packaging

- 25 kg
- 200 kg

Shelf life

UNIQ® SPERSE 580 U should be stored in a cool dry place. When kept in an original unopened container, it will keep up to 5 years from the date of manufacture.

UNIQ® SPERSE 586 U

Structured Polymer

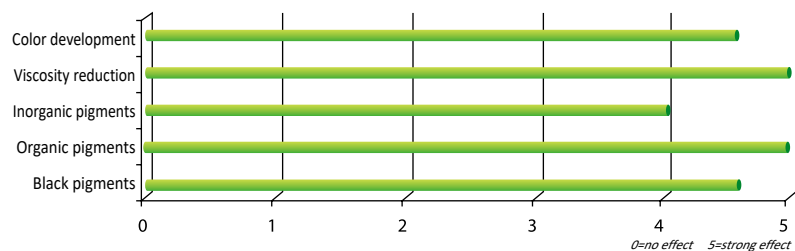

UNIQ® SPERSE 586 U is a wetting and dispersing additive for water base and solvent base, The dispersant suited for inorganic or organic pigments and resin free pigment concentrates. It shows good dispersibility and stability. In baking system it shows excellent high temperature resistance to yellowing. And good water-resistance in waterborne application.

Special Features

- Water borne and solvent borne, solvent free, UV applications
- Excellent dispersant for inorganic and organic pigments
- Suited for resin free pigment concentrates
- Outstanding high temperature and yellowing resistance
- Excellent water resistance performance
- Improve the gloss and color strength
- Prevent pigment settling

Product Specification

Active ingredients	100 %
Density 20°C	1.06 g/cm ³
Amine value	45.0 mg KOH/g
Acid value	3.0 mg KOH/g
Color	Max.8
Appearance	Brownish liquid

Packaging

- 25 kg
- 200 kg

Application

Architectural coatings	<input type="checkbox"/>
Wood and furniture coatings	<input type="checkbox"/>
Automotive and refinish coatings	<input checked="" type="checkbox"/>
Can/coil coatings	<input checked="" type="checkbox"/>
Industrial coatings	<input checked="" type="checkbox"/>
Pigment concentrates	<input checked="" type="checkbox"/>
Protective coatings	<input checked="" type="checkbox"/>

highly recommended ■
recommended □

Addition levels

- Amount of solid additive based on pigment (SOP):
- Inorganic pigments: 2 – 12 %
 - Titanium dioxides: 1 – 5 %
 - Organic pigments: 15 – 50 %
 - Carbon blacks: 20 – 100 %

The above recommended levels can be used for orientation and needs to be optimized by testing.

Shelf life

UNIQ® SPERSE 586 U should be stored in a cool dry place. When kept in an original unopened container, it will keep up to 5 years from the date of manufacture.

UNIQ® SPERSE 605 S

Polyester dispersant for solvent system

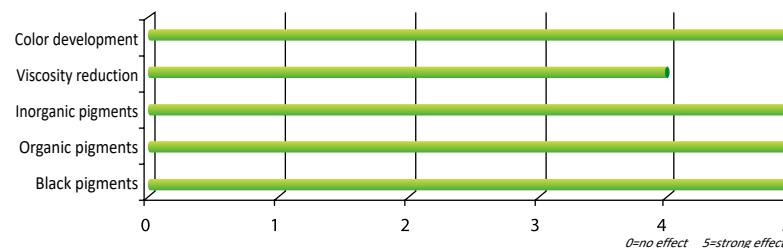

UNIQ® SPERSE 605 S is a wetting and dispersing additive for solvent based automotive and industrial coatings and pigment concentrates. Especially in two-pack PU, baking systems and CAB with excellent reduction of millbase viscosity. Gives excellent transparency with difficult pigments and with high channel black pigments it will give the best jetness with blue undertone.

Special Features

- Improve tint strength and chrome for organic and inorganic pigment
- Reduces viscosity of the mill bases
- Excellent for black jetness
- Good compatibility with CAB
- Suited for high temperature reactions like coil and baking system

Product Specification

Active ingredients	40.0 %
Solvent	n-BA
Density 20°C	0.96 g/cm ³
Acid Value	8.0 mg KOH/g
Amine value	19.0 mg KOH/g
Color	Max.13
Appearance	Brownish liquid

Packaging

- 25 kg
- 190 kg

Application

Architectural coatings	<input type="checkbox"/>
Wood and furniture coatings	<input checked="" type="checkbox"/>
Automotive and refinish coatings	<input checked="" type="checkbox"/>
Industrial Coatings	<input checked="" type="checkbox"/>
Protective coatings	<input checked="" type="checkbox"/>

highly recommended ■
recommended □

Addition levels

- Amount of solid additive based on pigment (SOP):
- Inorganic pigments: 2–5 %
 - Titanium dioxides: 1 – 3 %
 - Organic pigments: 15 – 40 %
 - Carbon blacks: 20 – 60 %

The above recommended levels can be used for orientation and needs to be optimized by testing.

Shelf life

UNIQ® SPERSE 605 S should be stored in a cool dry place. When kept in an original unopened container, it will keep up to 5 years from the date of manufacture.

UNIQ® SPERSE 615 S

Polyester dispersant for solvent system

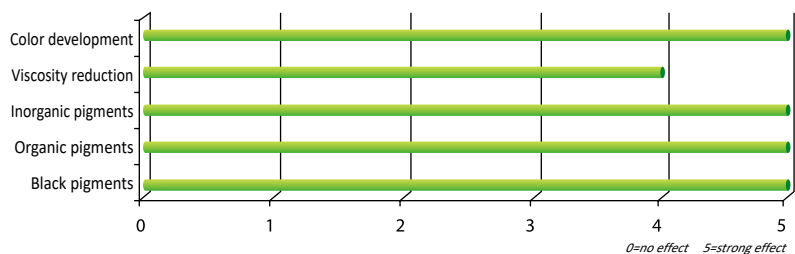

UNIQ® SPERSE 615 S is a wetting and dispersing additive for solvent based automotive and industrial coatings and pigment concentrates. Especially in two-pack PU, baking systems and CAB with excellent reduction of millbase viscosity. Gives excellent transparency with difficult pigments.

UNIQ® SPERSE 630 U

Structured Polymer

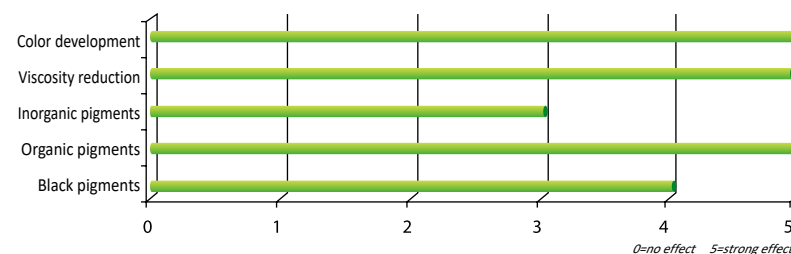

UNIQ® SPERSE 630 U is a wetting and dispersing additive mainly for water based applications. Suitable for resin free pigment concentrates. Especially developed for the grinding of organic pigment to give excellent transparency, color development, and high Chroma, improved the gloss, and shows good viscosity reduction.

UNIQ® SPERSE

Special Features

- Improve tint strength and chrome for organic and in organic pigment
- Reduces viscosity of the mill bases
- Excellent for black jetness
- Good compatibility with CAB
- Suited for high temperature reactions like coil and baking system

Application

Architectural coatings	
Wood and furniture coatings	■
Automotive and refinish coatings	■
Industrial coatings	■
Protective coatings	■

■ highly recommended
□ recommended

Special Features

- Water-borne applications
- Excellent dispersant for high performance organic pigment.
- Suited for resin free pigment concentrates
- Strong viscosity reduction
- High transparency and gloss
- Improves color development and Chroma

Application

Architectural coatings	□
Wood and furniture coatings	□
Automotive and refinish coatings	■
Industrial coatings	■
Protective coatings	□

■ highly recommended
□ recommended

Product Specification

Active ingredients	40.0 %
Solvent	n-BA
Density 20°C	0.96 g/cm ³
Acid Value	8.0 mg KOH/g
Amine value	19.0 mg KOH/g
Color	Max.13
Appearance	Brownish liquid

Addition levels

Amount of solid additive based on pigment (SOP):

- Inorganic pigments: 2 – 5 %
- Titanium dioxides: 1 – 3 %
- Organic pigments: 15 – 40 %
- Carbon blacks: 20 – 60 %

The above recommended levels can be used for orientation and needs to be optimized by testing.

Product Specification

Active ingredients	100 %
Density 20°C	1.08 g/cm ³
Amine value	40.0 mg KOH/g
Color	Max.13
Appearance	Brownish clear liquid

Addition levels

Amount of solid additive based on pigment (SOP):

- Inorganic pigments: 2 – 12 %
- Titanium dioxides: 1 – 4 %
- Organic pigments: 15 – 50 %
- Carbon blacks: 20 – 100 %

The above recommended levels can be used for orientation and needs to be optimized by testing.

Packaging

- 25 kg
- 190 kg

Shelf life

UNIQ® SPERSE 615 S should be stored in a cool dry place. When kept in an original unopened container, it will keep up to 5 years from the date of manufacture.

Packaging

- 25 kg
- 190 kg

Shelf life

UNIQ® SPERSE 630 U should be stored in a cool dry place. When kept in an original unopened container, it will keep up to 3 years from the date of manufacture.

UNIQ® SPERSE 650 U

Polymeric dispersant for solvent system

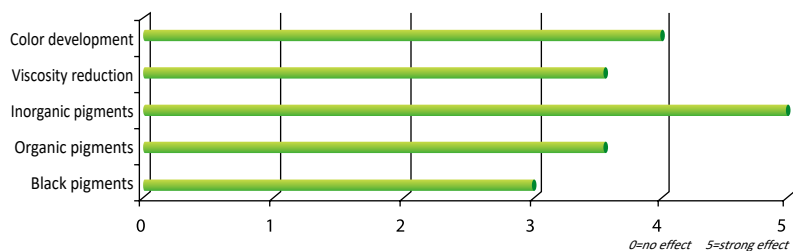

UNIQ® SPERSE 650 U is a wetting and dispersing additive based on new generation chemistry technology for solvent-, water based and solvent free applications. The dispersant is especially developed for the grinding of inorganic pigments, extender pigments and matting agents. Especially in water based systems it will prevent sedimentation of the inorganic pigments what can help you to eliminate or reduce the use of a rheology control agent.

Special Features

- Suitable for water-borne, solvent-borne and solvent-free application
- Wetting and dispersing agent especially suitable for inorganic, extender and matting agents pigments
- Suitable for color acceptance
- Reduce the viscosity of pigment paste and increase the pigment loading
- Improve color acceptance
- Improve the gloss and tinting strength

Application

Architectural coatings	<input type="checkbox"/>
Wood and furniture coatings	<input checked="" type="checkbox"/>
Automotive and refinish coatings	<input checked="" type="checkbox"/>
Industrial coatings	<input checked="" type="checkbox"/>
Protective coatings	<input checked="" type="checkbox"/>

highly recommended ■
recommended □

Product Specification

Active ingredients	100 %
Density 20°C	1.05 g/cm ³
Acid Value	14.0 mg KOH/g
Color	Max.13
Appearance	Reddish brown liquid

Addition levels

- Amount of solid additive based on pigment (SOP):
- Inorganic pigments: 2 – 5 %
 - Titanium dioxides: 1 – 3 %
 - Organic pigments: 15 – 40 %
 - Carbon blacks: 20 – 60 %

The above recommended levels can be used for orientation and needs to be optimized by testing.

Packaging

- 25 kg
- 190 kg

Shelf life

UNIQ® SPERSE 650 U should be stored in a cool dry place. When kept in an original unopened container, it will keep up to 5 years from the date of manufacture.

UNIQ® SPERSE 670 U

Structured Polymer

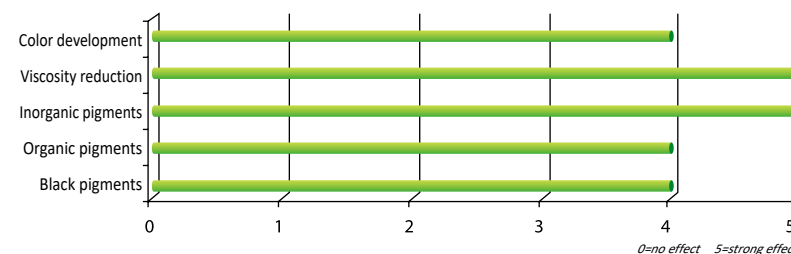

UNIQ® SPERSE 670 U is a new chemistry developed dispersing agents is suited for solvent-, water-based, UV and solvent-free coating system. The dispersant is very well suited for grinding transparent iron oxides. Also the dispersant is excellent suited for dispersing matting agents in water-based and solvent free systems like in UV to give excellent viscosity reduction, matting efficiency and storage stability without forming hard sediment.

Special Features

- Suitable for all types of solvent-, water-based, UV and solvent-free systems
- Excellent transparency and storage stability for transparent iron oxides
- Prevent settling of matting agents
- Excellent storage stability
- Improves the color and saturation of pigments

Application

Architectural coatings	<input type="checkbox"/>
Wood and furniture coatings	<input checked="" type="checkbox"/>
Automotive and refinish coatings	<input checked="" type="checkbox"/>
Industrial coatings	<input checked="" type="checkbox"/>
Pigment concentrates	<input type="checkbox"/>
Protective coatings	<input type="checkbox"/>

highly recommended ■
recommended □

Product Specification

Active ingredients	100 %
Density 20°C	1.12 g/cm ³
Acid Value	42 mg KOH/g
Amine value	70 mg KOH/g
Appearance	Yellow transparent liquid

Addition levels

- Amount of solid additive based on pigment (SOP):
- Inorganic pigments: 2 - 15 %
 - Titanium dioxides: 1 - 5 %
 - Organic pigments: 15 - 50 %
 - Carbon blacks: 20 - 100 %

The above recommended levels can be used for orientation and needs to be optimized by testing.

Packaging

- 25 kg
- 200 kg

Shelf life

UNIQ® SPERSE 670 U should be stored in a cool dry place. When kept in an original unopened container, it will keep up to 5 years from the date of manufacture.

UNIQ® SPERSE 680 U

Structured Polymer

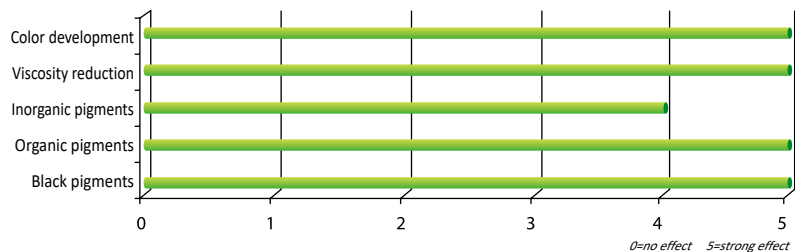

UNIQ® SPERSE 680 U is a wetting and dispersing additive for water-, solvent- and solvent free based applications. The dispersant is especially developed for grinding organic pigments, but gives also excellent performances and jetness for HCC carbon black. The dispersant is also suited for inorganic pigments and the dispersant can be used for the preparation of resin free pigment concentrates.

UNIQ® SPERSE 685 U

Structured Polymer

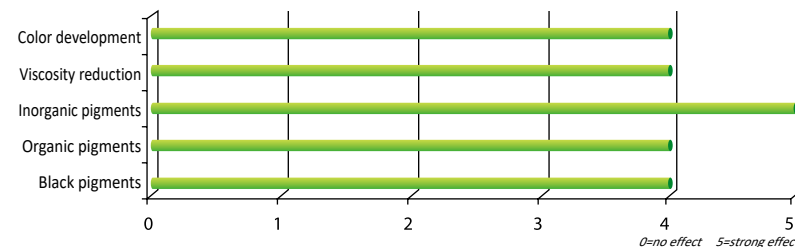

UNIQ® SPERSE 685 U is a wetting and dispersing additive based on new generation chemistry technology for solvent-, water based and solvent free applications. The dispersant is especially developed for the grinding of carbon black to give excellent jetness development. Also very well suited for organic yellow and organic red pigments.

UNIQ® SPERSE

Special Features

- Suitable for water-, solvent- and solvent-free application
- Wetting and dispersing agent suitable for all pigments
- Gives excellent jetness with HCC black pigments
- Strong viscosity reduction
- High transparency and gloss
- Improves hiding power

Application

Architectural coatings	<input type="checkbox"/>
Wood and furniture coatings	<input type="checkbox"/>
Automotive and refinish coatings	<input checked="" type="checkbox"/>
Industrial coatings	<input checked="" type="checkbox"/>
Pigment concentrates	<input checked="" type="checkbox"/>
Protective coatings	<input checked="" type="checkbox"/>

highly recommended ■
recommended □

Special Features

- Suitable for water-borne, solvent-borne and solvent-free application
- Wetting and dispersing agent suitable for all pigments
- Gives excellent jetness with HCC black pigments
- Reduce the viscosity of pigment paste and increase the pigment loading

Application

Architectural coatings	<input type="checkbox"/>
Wood and furniture coatings	<input checked="" type="checkbox"/>
Automotive and refinish coatings	<input checked="" type="checkbox"/>
Industrial coatings	<input checked="" type="checkbox"/>
Protective coatings	<input checked="" type="checkbox"/>

highly recommended ■
recommended □

Product Specification

Active ingredients	100 %
Density 20°C	1.08 g/cm ³
Acid Value	9.0 mg KOH/g
Amine value	65.0 mg KOH/g
Color	Max. 8
Appearance	Brownish clear liquid

Addition levels

Amount of solid additive based on pigment (SOP):

- Inorganic pigments: 2 - 5 %
- Titanium dioxides: 1 - 3 %
- Organic pigments: 15 - 40 %
- Carbon blacks: 20 - 80 %

The above recommended levels can be used for orientation and needs to be optimized by testing.

Product Specification

Active ingredients	100 %
Density 20°C	1.1 g/cm ³
Acid Value	12.0 mg KOH/g
Color	Max. 8
Appearance	Brownish clear liquid

Addition levels

Amount of solid additive based on pigment (SOP):

- Inorganic pigments: 2 - 5 %
- Titanium dioxides: 1 - 3 %
- Organic pigments: 15 - 50 %
- Carbon blacks: 20 - 100 %

The above recommended levels can be used for orientation and needs to be optimized by testing.

Packaging

- 25 kg
- 200 kg

Shelf life

UNIQ® SPERSE 680 U should be stored in a cool dry place. When kept in an original unopened container, it will keep up to 5 years from the date of manufacture.

Packaging

- 25 kg
- 200 kg

Shelf life

UNIQ® SPERSE 685 U should be stored in a cool dry place. When kept in an original unopened container, it will keep up to 5 years from the date of manufacture.

UNIQ® SPERSE 690 W

Block polymer dispersant

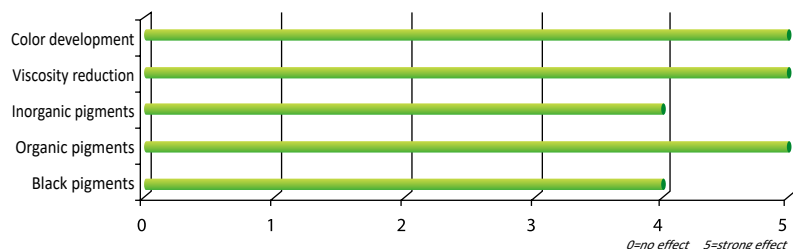

UNIQ® SPERSE 690 W is a wetting and dispersing additive for aqueous coating systems, also suitable for resin free pigment concentrates, suitable for all pigments.

UNIQ® SPERSE 690 W stabilizes pigments by means of steric stabilization. Well stabilized pigments with small particle sizes will result in high gloss levels, improved color strength and hiding power, improved transparency and reduction of the viscosity. As a matter of fact higher pigment loading pigment concentrates can be achieved.

Special Features

- Water borne applications
- Excellent dispersant for inorganic and organic pigments
- Suited for resin free pigment concentrates
- Strong viscosity reduction
- Prevents flooding and floating
- Improves hiding power
- Excellent early water resistance

Application

Architectural coatings	■
Wood and furniture coatings	■
Automotive and refinish coatings	■
Industrial coatings	■
Pigment concentrates	■
Protective coatings	■

highly recommended ■
recommended □

Product Specification

Active ingredients	40.0 %
Density 20°C	1.07 g/cm ³
Acid value	15.0 mg KOH/g
Amine value	15.0 mg KOH/g
Color	Max. 6
Appearance	Slight brownish clear liquid

Addition levels

Amount of solid additive based on pigment (SOP):

- Inorganic pigments: 2 - 5 %
- Titanium dioxides: 2 - 5 %
- Organic pigments: 10 - 40 %
- Carbon blacks: 20 - 100 %

The above recommended levels can be used for orientation and needs to be optimized by testing.

Packaging

- 25 kg
- 200 kg
- 1000 kg

Shelf life

UNIQ® SPERSE 690 W should be stored in a cool dry place. When kept in an original unopened container, it will keep up to 3 years from the date of manufacture.

UNIQ® SPERSE 700 S

Pigment dispersing synergist

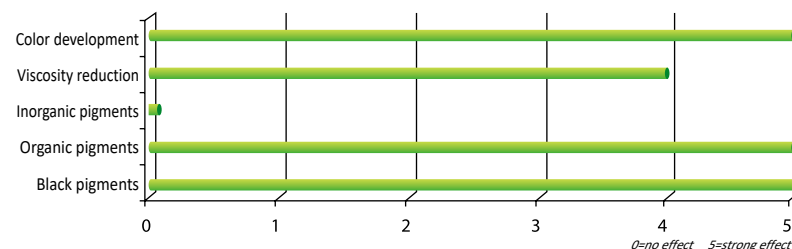

UNIQ® SPERSE 700 S is a pigmentary dispersing synergist used in conjunction with UNIQ® SPERSE 500 and 600 series high molecular weight dispersing agents to improve the pigment grinding dispersion, stability and color development. The synergist is mainly suitable for black, green, blue and violet pigments.

Special Features

- Solvent borne applications
- Excellent dispersant for organic blue, black, green pigments
- Gives good viscosity reduction
- Improves transparency
- Improves color development
- Reduce or protect color flooding and floating

Application

Architectural coatings	■
Wood and furniture coatings	■
Automotive and refinish coatings	■
Industrial coatings	■
Pigment concentrates	■
Protective coatings	■

highly recommended ■
recommended □

Product Specification

Active ingredients	100 %
Density 20°C	1.26 g/cm ³
Appearance	Blueish powder

Addition levels

Amount of synergist additive in conjunction with HMWD agents in ratio 1:2, 1:4 and 1:9

The above recommended levels can be used for orientation and needs to be optimized by testing.

Packaging

- 10 kg

Shelf life

UNIQ® SPERSE 700 S should be stored in a cool dry place. When kept in an original unopened container, it will keep up to 3 years from the date of manufacture.

UNIQ® SPERSE 710 S

Polyester phosphoric dispersant for solvent based system

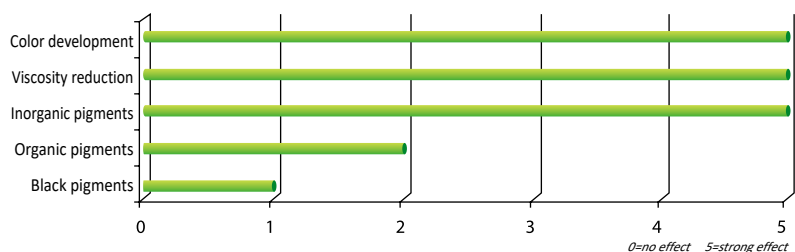

UNIQ® SPERSE 710 S is a wetting and dispersing additive for solvent based coating systems. The dispersant is especially suitable for inorganic pigments, extender pigments. For TiO₂ millbase viscosities will be strong reduced so higher pigment loading in the mill base process can be achieved.

UNIQ® SPERSE 711 S

Polyester phosphoric dispersant for solvent based system

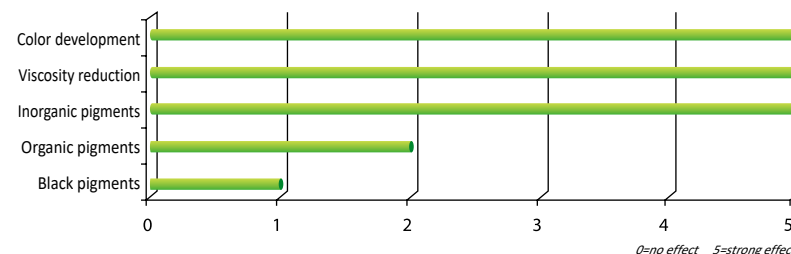

UNIQ® SPERSE 711 S is a wetting and dispersing additive for solvent based coating systems. The dispersant is especially suitable for inorganic pigments, extender pigments. For TiO₂ millbase viscosities will be strong reduced so higher pigment loading in the mill base process can be achieved.

UNIQ® SPERSE

Special Features

- Solvent based applications
- Wetting and dispersing agent of TiO₂ and inorganic pigment
- Reduce the viscosity of pigment paste and increase the pigment loading
- Increase the hiding power of TiO₂
- Improve optical whiteness
- Improve the gloss and tinting strength

Application

Architectural coatings	<input type="checkbox"/>
Wood and furniture coatings	<input checked="" type="checkbox"/>
Automotive and refinish coatings	<input checked="" type="checkbox"/>
Industrial coatings	<input checked="" type="checkbox"/>
Protective coatings	<input checked="" type="checkbox"/>

highly recommended ■
recommended □

Special Features

- Solvent based applications
- Wetting and dispersing agent of TiO₂ and inorganic pigment
- Reduce the viscosity of pigment paste and increase the pigment loading
- Increase the hiding power of TiO₂
- Improve optical whiteness
- Improve the gloss and tinting strength

Application

Architectural coatings	<input type="checkbox"/>
Wood and furniture coatings	<input checked="" type="checkbox"/>
Automotive and refinish coatings	<input checked="" type="checkbox"/>
Can/coil coatings	<input checked="" type="checkbox"/>
Protective coatings	<input checked="" type="checkbox"/>

highly recommended ■
recommended □

Product Specification

Active ingredients	50.0 %
Solvent	PMA/Hydrocarbons C9 Aromatics
Density 20°C	0.99 g/cm ³
Acid value	80.0 mg KOH/g
Color	Max.3
Appearance	Slight yellowish clear liquid

Addition levels

Amount of solid additive based on pigment (SOP):

- Inorganic pigments: 2 - 5 %
- Titanium dioxides: 1 - 3 %

The above recommended levels can be used for orientation and needs to be optimized by testing.

Product Specification

Active ingredients	100 %
Density 20°C	1.07 g/cm ³
Acid value	140.0 mg KOH/g
Color	Max. 5
Appearance	Slight yellowish clear liquid

Addition levels

Amount of solid additive based on pigment (SOP):

- Inorganic pigments: 2 - 5 %
- Titanium dioxides: 1 - 3 %

The above recommended levels can be used for orientation and needs to be optimized by testing.

Packaging

- 25 kg
- 180 kg

Shelf life

UNIQ® SPERSE 710 S should be stored in a cool dry place. When kept in an original unopened container, it will keep up to 5 years from the date of manufacture.

Packaging

- 25 kg
- 200 kg

Shelf life

UNIQ® SPERSE 711 S should be stored in a cool dry place. When kept in an original unopened container, it will keep up to 5 years from the date of manufacture.

UNIQ® SPERSE 730 U

Polyester acrylic acid dispersant

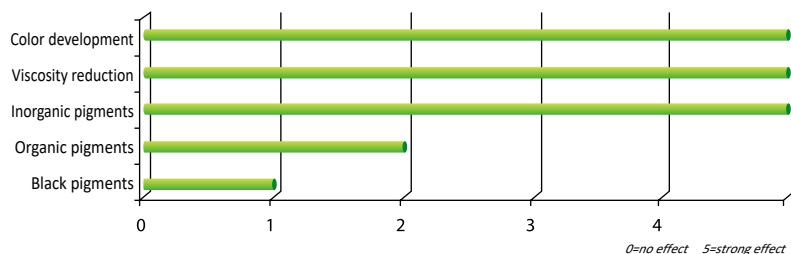

UNIQ® SPERSE 730 U is a wetting and dispersing additive for solvent-, water based and solvent free applications. The dispersant is especially suitable for inorganic pigments, extender pigments. For TiO₂ millbase viscosities will be strong reduced so higher pigment loading in the mill base process can be achieved. When used in water based application it is advisable to achieve the best viscosity reduction properties and stability to adjust the pH to 8 - 8.5

UNIQ® SPERSE 740 U

W&D agent

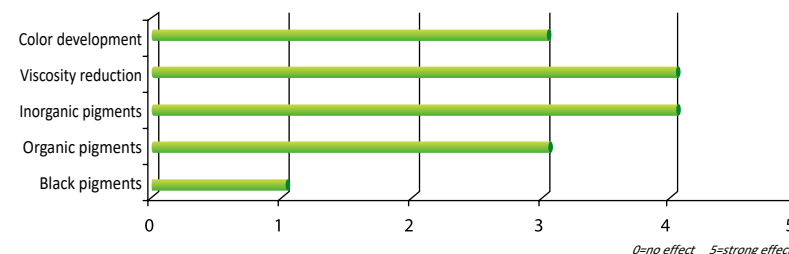

UNIQ® SPERSE 740 U is a wetting and dispersing additive for solvent-borne applications. It is very suitable for industrial, architectural and protection coatings. It can give excellent dispersing performance to inorganic, organic pigments or bentonite. Strong viscosities reduction so higher pigment and filler loading in the grinding process can be achieved. It can also improve the transparency and hiding power.

UNIQ® SPERSE

Special Features

- Suitable for water-borne, solvent-borne and solvent-free application
- Wetting and dispersing agent especially of TiO₂ and inorganic pigment
- Reduce the viscosity of pigment paste and increase the pigment loading
- Increase the hiding power of TiO₂
- Improve the optical whiteness
- Improve the gloss and tinting strength

Application

Architectural coatings	<input type="checkbox"/>
Wood and furniture coatings	<input checked="" type="checkbox"/>
Automotive and refinish coatings	<input checked="" type="checkbox"/>
Can/coil coatings	<input checked="" type="checkbox"/>
Protective coatings	<input checked="" type="checkbox"/>

highly recommended
recommended

Special Features

- Wetting and dispersing agent for inorganic pigments, organic pigments and bentonite
- Reduce the viscosity
- Increase the pigment and filler loading
- Improve the transparency and hiding power
- Excellent wetting

Application

Architectural coatings	<input checked="" type="checkbox"/>
Wood and furniture coatings	<input checked="" type="checkbox"/>
Automotive and refinish coatings	<input checked="" type="checkbox"/>
Can/coil coatings	<input checked="" type="checkbox"/>
Protective coatings	<input checked="" type="checkbox"/>

highly recommended
recommended

Product Specification

Active ingredients	100 %
Density 20°C	1.13 g/cm ³
Acid value	60.0 mg KOH/g
Color	Max. 10
Appearance	Brownish clear liquid

Addition levels

Amount of solid additive based on pigment (SOP):

- Inorganic pigments: 2 – 5 %
- Titanium dioxides: 1 – 3 %

The above recommended levels can be used for orientation and needs to be optimized by testing.

Product Specification

Active ingredients	100 %
Density 20°C	0.99 g/cm ³
Acid value	60.0 mg KOH/g
Amine value	33.0 mg KOH/g
Color	Max. 8
Appearance	Brownish sticky liquid

Addition levels

Amount of solid additive based on pigment (SOP):

- Inorganic pigments: 1 – 2 %
- TiO₂: 0.5 – 1 %
- Organic pigments: 1 – 5 %
- Bentonite: 30 – 50 %

The above recommended levels can be used for orientation and needs to be optimized by testing.

Packaging

- 25 kg
- 200 kg

Shelf life

UNIQ® SPERSE 730 U should be stored in a cool dry place. When kept in an original unopened container, it will keep up to 5 years from the date of manufacture.

Packaging

- 30 kg
- 190 kg

Shelf life

UNIQ® SPERSE 740 U should be stored in a cool dry place. When kept in an original unopened container, it will keep up to 5 years from the date of manufacture.

UNIQ® SPERSE 745 S

W&D agent

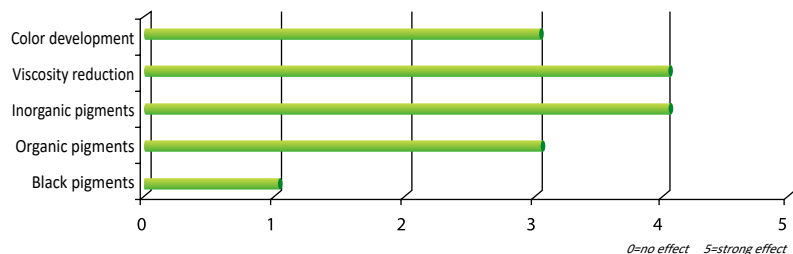

UNIQ® SPERSE 745 S is a wetting and dispersing additive for solvent-borne applications. It is very suitable for industrial, architectural and protection coatings. It can give excellent dispersing performance to inorganic, organic pigments or bentonite. Strong viscosities reduction so higher pigment and filler loading in the grinding process can be achieved. It can also improve the transparency and hiding power.

UNIQ® SPERSE 764 S

W&D agent to prevent flooding and floating of pigments

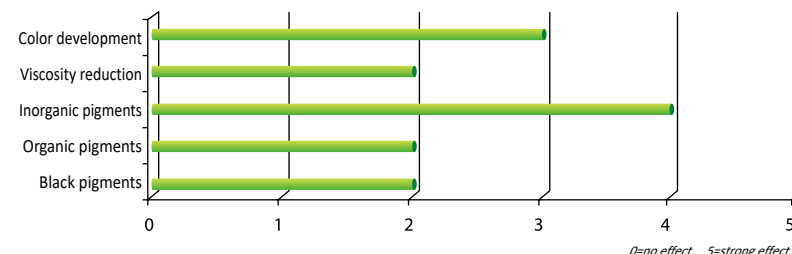

UNIQ® SPERSE 764 S is controlled flocculating wetting and dispersing additive for solvent-borne, medium-polarity to high-polarity coatings to prevent the flooding/floating of titanium dioxide in combination with colored pigments.

UNIQ® SPERSE

Special Features

- Wetting and dispersing agent for inorganic pigments, organic pigments and bentonite
- Reduce the viscosity
- Increase the pigment and filler loading
- Improve the transparency and hiding power
- Excellent wetting

Application

Architectural coatings	■
Wood and furniture coatings	■
Automotive and refinish coatings	■
Can/coil coatings	■
Protective coatings	■

highly recommended ■
recommended □

Special Features

- Solvent application
- Prevention of flooding and floating
- Reduce dispersion time
- Reduce tendency of Bernard cells
- Stabilization of the pigment dispersion
- Decrease pigment sedimentation
- Help orientation of matting agent and aluminum
- Silicone free

Application

Architectural coatings	■
Wood and furniture coatings	■
Automotive and refinish coatings	■
Can/coil coatings	■
Protective coatings	■

highly recommended ■
recommended □

Product Specification

Active ingredients	50.0 %
Density 20°C	0.86 g/cm ³
Acid value	35.0 mg KOH/g
Amine value	20.0 mg KOH/g
Color	Max. 8
Appearance	Brownish liquid

Addition levels

Amount of solid additive based on pigment (SOP):

- Inorganic pigments: 1 – 2 %
- TiO₂: 0.5 – 1 %
- Organic pigments: 1 – 5 %
- Bentonite: 30 – 50 %

The above recommended levels can be used for orientation and needs to be optimized by testing.

Product Specification

Active ingredients	50.0 %
Solvent	Hydrocarbons C9 aromatics/Xylene/MIBK
Density 20°C	0.95 g/cm ³
Acid value	140 mg KOH/g
Color	Max. 12
Appearance	Brownish liquid

Addition levels

- Amount of solid additive based on pigment (SOP):
- Inorganic pigments: 1.5 – 5 %
 - Titanium dioxides: 0.2 – 2 %
 - Organic pigments: 5 – 10 %

The above recommended levels can be used for orientation and needs to be optimized by testing.

Packaging

- 22 kg
- 170 kg

Shelf life

UNIQ® SPERSE 745 S should be stored in a cool dry place. When kept in an original unopened container, it will keep up to 5 years from the date of manufacture.

Packaging

- 25 kg
- 180 kg

Shelf life

UNIQ® SPERSE 764 S should be stored in a cool dry place. When kept in an original unopened container, it will keep up to 5 years from the date of manufacture.

UNIQ® SPERSE 765 S

W&D agent with silicone to prevent flooding and floating of pigments

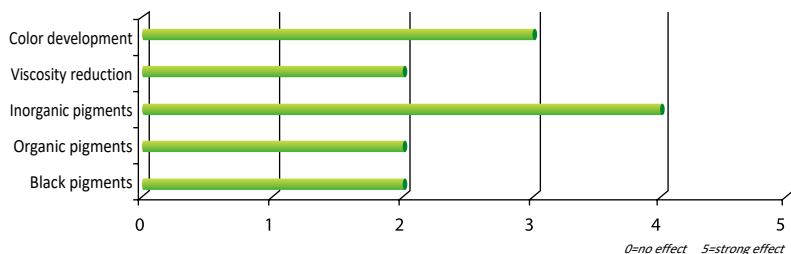

UNIQ® SPERSE 765 S is controlled flocculating wetting and dispersing additive for solvent-borne, medium-polarity to high-polarity coatings to prevent the flooding/floating of titanium dioxide in combination with colored pigments. Contains silicone to improve flooding/floating behavior.

UNIQ® SPERSE 770 U

Low molecular weight dispersant for solvent based

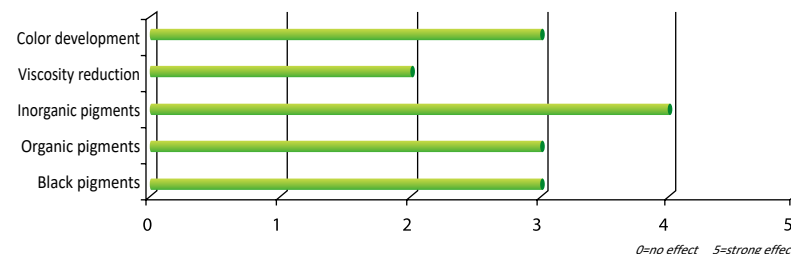

UNIQ® SPERSE 770 U is wetting and dispersing additive for solvent-based coatings and pigment concentrates on the basis of alkyd resins. The additive is suitable for all pigments. Also well suited for Alkyd/melamine coating systems.

UNIQ® SPERSE

Special Features

- Solvent application
- Prevention of flooding and floating
- Reduce dispersion time
- Reduce tendency of Bernard cells
- Stabilization of the pigment dispersion
- Decrease pigment sedimentation
- Help orientation of matting agent and aluminum

Application

Architectural coatings	■
Wood and furniture coatings	■
Automotive and refinish coatings	■
Can/coil coatings	■
Protective coatings	■

highly recommended ■
recommended □

Special Features

- Dispersant for organic and inorganic pigment, especially inorganic pigment
- Prevention of flooding and floating
- Reduce dispersion time
- Suitable for low polarity system like TPA and NC

Application

Architectural coatings	■
Wood and furniture coatings	■
Automotive and refinish coatings	□
Baking coatings	■
Protective coatings	□

highly recommended ■
recommended □

Product Specification

Active ingredients	50.0 %
Solvent	Hydrocarbons C9 aromatics/Xylene/MIBK
Density 20°C	0.95 g/cm ³
Acid value	125.0 mg KOH/g
Color	Max. 12
Appearance	Brownish liquid

Addition levels

Amount of solid additive based on pigment (SOP):

- Inorganic pigments: 1.5 – 5 %
- Titanium dioxides: 0.2 – 2 %
- Organic pigments: 5 – 10 %

The above recommended levels can be used for orientation and needs to be optimized by testing.

Product Specification

Active ingredients	100 %
Density 20°C	0.95 g/cm ³
Amine value	80.0 mg KOH/g
Color	Max.13
Appearance	Brownish liquid

Addition levels

Amount of solid additive based on pigment (SOP):

- Inorganic pigments: 0.2 - 5 %
- Titanium dioxides: 1 - 3 %
- Organic pigments: 2 - 5 %
- Bentonites 15 - 25 %

The above recommended levels can be used for orientation and needs to be optimized by testing.

Packaging

- 25 kg
- 180 kg

Shelf life

UNIQ® SPERSE 765 S should be stored in a cool dry place. When kept in an original unopened container, it will keep up to 5 years from the date of manufacture.

Packaging

- 25 kg
- 190 kg

Shelf life

UNIQ® SPERSE 770 U should be stored in a cool dry place. When kept in an original unopened container, it will keep up to 5 years from the date of manufacture.



UNIQ[®] LIGHT

UNIQ[®] LIGHT 951

Blended Hals and UV absorber

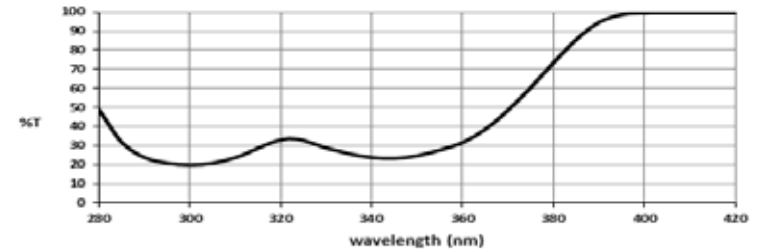

General **UNIQ[®] LIGHT 951** is a liquid light stabilizer blend developed specifically for coatings. Its high thermal stability and permanence makes it suitable for coatings exposed to high bake temperatures and extreme environmental conditions. It has been designed to fulfill the high cost/performance and durability requirements of trade sales and industrial applications. Its broad UV absorption allows efficient protection of light sensitive substrates such as wood and plastics.

Special Features

- Blend Liquid
- Broad UV absorption
- Broad application range

Application

Architectural coatings	<input type="checkbox"/>
Wood and furniture coatings	<input checked="" type="checkbox"/>
Automotive and refinish coatings	<input checked="" type="checkbox"/>
Can/coil coatings	<input checked="" type="checkbox"/>
Protective coatings	<input type="checkbox"/>

highly recommended ■
recommended □

Product Specification

Dynamic viscosity	7000 mPas
Density 20°C	1.10 g/cm ³
Appearance	Slight yellowish liquid

Addition levels

OEM/Refinish coatings	2.0 – 5.0 %
Industrial coatings	1.0 – 3.0 %
Wood Coatings	2.0 – 5.0%

Packaging

- 25 kg
- 200 kg

Shelf life

UNIQ[®] LIGHT 951 should be stored in a cool dry place. When kept in an original unopened container, it will keep up to 3 years from the date of manufacture.

UNIQ® LIGHT 923

Hindered Amine Light Stabilizer



General **UNIQ® LIGHT 923** is a new liquid hinder amine light stabilizer especially developed for coatings. It is based on an aminoether function which prevents possible interactions with acidic paint ingredients such as catalysts. The efficiency of **UNIQ® LIGHT 923** provides significantly extended life time to coatings by minimizing paint defects such as cracking and loss of gloss.

The performance of **UNIQ® LIGHT 923** can be significantly improved when used in combination with a UV absorbers such as **UNIQ® LIGHT 930** and **UNIQ® LIGHT 940**. These synergistic combinations give coatings superior protection against gloss reduction, cracking, blistering, delamination and colour change. Possible interactions of **UNIQ® LIGHT 923** with paint ingredients such as acid catalysts should be carefully evaluated.

Special Features

- Liquid
- Suitable for solvent-, water based and UV coatings
- Suitable for clear and pigmented coatings
- Minimize paint defects like crack and loss of gloss

Application

Architectural coatings	■
Wood and furniture coatings	■
Automotive and refinish coatings	■
Can/coil coatings	■
Protective coatings	■

highly recommended ■
recommended □

Product Specification

Dynamic viscosity	3000 mPas
Density 20°C	0.97 g/cm ³
Appearance	Slight yellowish liquid

Addition levels

OEM/Refinish coatings	1.0 – 3.0 %
Industrial coatings	0.5 – 2.0 %

Packaging

- 25 kg
- 190 kg

Shelf life

UNIQ® LIGHT 923 should be stored in a cool dry place. When kept in an original unopened container, it will keep up to 2 years from the date of manufacture.

UNIQ® LIGHT 930

UV absorber

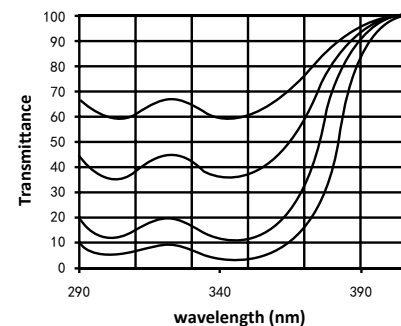

Explanation for 40 µm film:

- Top line: 0.001% LS930, corresponds to 0.25%
- Second line: 0.002% LS930, corresponds to 0.50%
- Third line: 0.004% LS930, corresponds to 1.0%
- Bottom line: 0.006% LS930, corresponds to 1.5%

General **UNIQ® LIGHT 930** is a liquid UV absorber of the hydroxyphenyl-benzotriazole class specifically developed for coatings. The product is miscible with all common solvents but also easily incorporated into water borne systems. In view of the high durability demands, its high temperature and extraction resistance makes it especially suitable for industrial and automotive coatings. Because of its broad UV absorption, **UNIQ® LIGHT 930** also provides efficient protection to light sensitive substrates such as wood and plastics.

Special Features

- Liquid
- Suitable for solvent- and water based
- Broad UV absorption
- Especially suitable for clear coatings

Application

Architectural coatings	□
Wood and furniture coatings	■
Automotive and refinish coatings	■
Can/coil coatings	■
Protective coatings	■

highly recommended ■
recommended □

Product Specification

Dynamic viscosity	7400 mPas
Density 20°C	1.17 g/cm ³
Appearance	Yellowish to slight amber viscous liquid

Addition levels

OEM/Refinish coatings	1.0 – 3.0 %
Industrial coatings	1.0 – 3.0 %
Water based coatings	1.0 – 3.0 %

Packaging

- 25 kg
- 200 kg

Shelf life

UNIQ® LIGHT 930 should be stored in a cool dry place. When kept in an original unopened container, it will keep up to 3 years from the date of manufacture.

UNIQ[®] LIGHT 992

Hindered Amine Light Stabilizer



General UNIQ[®] LIGHT 992 is a liquid hinder amine light stabilizer especially developed for coatings. It is an almost pure mixture of the two active ingredients. It is this combination that keeps the product liquid, unlike the pure diester which tends to solidify, even at room temperature. The efficiency of UNIQ[®] LIGHT 992 provides significantly extended life time to coatings by minimizing paint defects such as cracking and loss of gloss.

The performance of UNIQ[®] LIGHT 992 can be significantly improved when used in combination with a UV absorbers such as UNIQ[®] LIGHT 930 and UNIQ[®] LIGHT 940. These synergistic combinations give coatings superior protection against gloss reduction, cracking, blistering, delamination and colour change.

Possible interactions of UNIQ[®] LIGHT 992 with paint ingredients such as acid catalysts should be carefully evaluated.

Special Features

- Liquid
- Suitable for solvent-, water based and UV coatings
- Suitable for clear and pigmented coatings
- Minimize paint defects like crack and loss of gloss

Application

Architectural coatings	□
Wood and furniture coatings	■
Automotive and refinish coatings	■
Can/coil coatings	■
Protective coatings	■

highly recommended ■
recommended □

Product Specification

Dynamic viscosity	400 mPas
Appearance	Slightly yellow liquid

Addition levels

- OEM/Refinish coatings 1.0 – 3.0 %
- Industrial coatings 0.5 – 2.0 %
- UV coatings 0.5 – 3.0 %

Packaging

- 25 kg
- 190 kg

Shelf life

UNIQ[®] LIGHT 992 should be stored in a cool dry place. When kept in an original unopened container, it will keep up to 3 years from the date of manufacture.

UNIQ[®] LIGHT 940

UV absorber

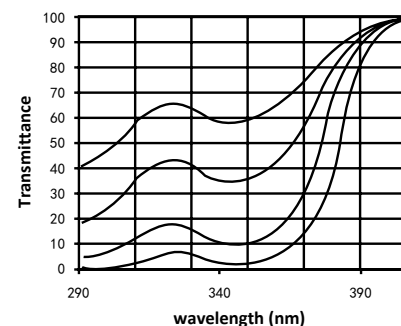

Explanation for 40 µm film:

- Top line: 0.001% LS930, corresponds to 0.25%
- Second line: 0.002% LS930, corresponds to 0.50%
- Third line: 0.004% LS930, corresponds to 1.0%
- Bottom line: 0.006% LS930, corresponds to 1.5%

General UNIQ[®] LIGHT 940 is a liquid hydroxyphenyl-triazine (HPT) UV absorber designed to fulfill the high performance and durability needs of solventborne, UV-curing and water based systems. Its low color and stability make it an excellent choice for all coatings where low color characteristics are ideal for use in combination with the newest generation photoinitiators to provide durable UV clear coats.

Special Features

- Liquid
- Suitable for solvent-, UV curing and water based
- high photo-stability for long term performance
- low migration effect, high efficiency
- excellent heat stability

Application

Architectural coatings	□
Wood and furniture coatings	■
Automotive and refinish coatings	■
Can/coil coatings	■
Protective coatings	■

highly recommended ■
recommended □

Product Specification

Density 20°C	1.07 g/cm ³
Appearance	Slight Yellowish liquid

Addition levels

- OEM/Refinish coatings 1.0 – 3.0 %
- Industrial coatings 1.0 – 3.0 %
- Water based coatings 1.0 – 3.0 %

Packaging

- 25 kg

Shelf life

UNIQ[®] LIGHT 940 should be stored in a cool dry place. When kept in an original unopened container, it will keep up to 1 years from the date of manufacture.



Specialties

UNIQ[®]VIS is our brand for some special products, like rheology control agents and conductivity agents.

UNIQ[®] VIS 840 W

Additive to reduce drying-out of aqueous pigment concentrates



Special Features

- Water borne applications
- Based on modified urea chemistry
- Optimum control of water evaporation
- Slow down the dry-out of pigment concentrates

Product Specification

Active ingredients	90 %
Solvent	Water
Density 20°C	1.14 g/cm ³
Appearance	Yellowish liquid

Packaging

- 25 kg
- 190 kg

Application

Architectural coatings	■
Wood and furniture coatings	
Automotive and refinish coatings	
Can/coil coatings	
Pigment concentrates	■
Protective coatings	

highly recommended ■
recommended □

Addition levels

Coatings
Pigment paste: 3 -10 %

Can be added at any stage of production

Shelf life

UNIQ[®]VIS 840 W should be stored in a cool dry place. When kept in an original unopened container, it will keep up to 2 years from the date of manufacture.

UNIQ[®] VIS 880 S

Additive to increase the conductivity of electrostatically sprayed solvent coating



Special Features

- Solvent borne applications
- Increase the conductivity of the paints(reduce the electrical resistance)
- Halogen free
- Stable even at low temperature
- Maintain film properties like adhesion, does not cause yellowing and stabilizes viscosity

Product Specification

Active ingredients	54 %
Solvent	n-butanol
Density 20°C	0.90g/cm ³
Appearance	Light yellowish liquid

Packaging

- 25 kg
- 170 kg

Application

Architectural coatings	
Wood and furniture coatings	■
Automotive and refinish coatings	■
Can/coil coatings	■
Protective coatings	□

highly recommended ■
recommended □

Addition levels

Coatings and inks
Suggest to pre-mix with isobutanol at 1:1 or 1:2 in non polar system, which are thinned only with mineral spirits or xylene.
Total formulation 0.1 -2 %

Can be added at the end of production

Shelf life

UNIQ[®] VIS 880 S should be stored in a cool dry place. When kept in an original unopened container, it will keep up to 5 years from the date of manufacture.



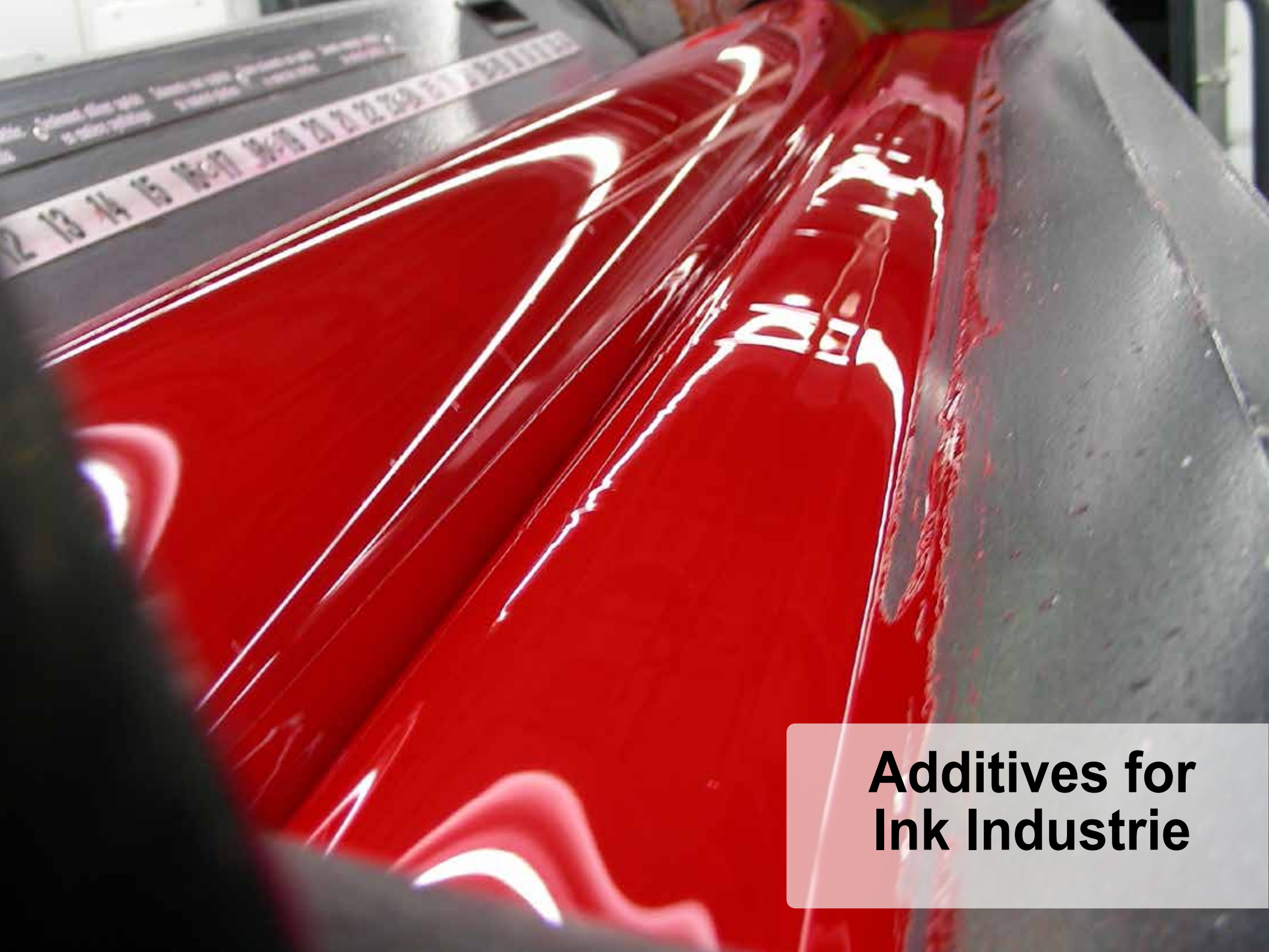

Additives for Ink Industrie



UNIQ[®] SPERSE



UNIQ[®] SPERSE 9012

Block Polymeric Dispersant

UNIQ[®] SPERSE 9012 is a 40% active polymeric dispersant which will improve pigment dispersion and stability in water based coatings and inks.

Special Features

- Suitable for resin-free & resin containing dispersions
- Good viscosity reduction and improved pigment concentration
- Improved production efficiency
- Improved pigment wetting
- Higher gloss and color strength

Application

Water based ink	■
Water based digital ink	■

Product Specification

Active ingredients	40.0 %
Density 20°C	1.07 g/cm ³
Acid value	9.0 mg KOH/g
Amine value	16.0 mg KOH/g
Color	Max.6
Appearance	Slight brownish clear liquid

Addition levels

UNIQ[®] SPERSE 9012 should be dissolved in mill base diluent before the addition of pigment.

For inks the dosage level required could be considerably higher and dosages of 2 mg active dispersant on weight of pigment should be considered. This is simply the surface area divided by 5.

The general dosage is as:
% AOWP=10-30.

Packaging

- 25 kg
- 200 kg

Shelf life

UNIQ[®] SPERSE 9012 should be stored in a cool dry place. When kept in an original unopened container, it will keep up to 3 years from the date of manufacture.

UNIQ® SPERSE 9315

Polymeric Dispersant

UNIQ® SPERSE 9315 is a 50% active polymeric dispersant in ethyl acetate which will improve pigment dispersion and stability in solvent based inks.

Special Features

- Improved production efficiency
- Improved pigment concentration
- Improved pigment wetting
- Higher gloss and color strength
- Improved rheology

Application

Solvent based ink	■
-------------------	---

Product Specification

Solvent	Ethyl Acetate
Active ingredients	50.0 %
Density 20°C	0.94 g/cm ³
Amine value	17.0 mg KOH/g
Color	Max.10
Appearance	Yellow to amber liquid

Addition levels

UNIQ® SPERSE 9315 should be dissolved in mill base diluent before the addition of pigment.

For inks the dosage level required could be considerably higher and dosages of 2 mg active dispersant on weight of pigment should be considered. This is simply the surface area divided by 5.

Packaging

- 25 kg
- 190 kg

Shelf life

UNIQ® SPERSE 9315 should be stored in a cool dry place. When kept in an original unopened container, it will keep up to 5 years from the date of manufacture.

UNIQ® SPERSE 9330

Polymeric Dispersant

UNIQ® SPERSE 9330 is an active polymeric dispersant which will improve pigment dispersion and stability in water based, solvent based and UV based inks.

Special Features

- Universal application
- Suitable for TiO₂, inorganic pigments and fillers dispersion
- Good viscosity reduction, increased pigment loading and improve production effect
- Improved whiteness of TiO₂ paste, good opacity.
- Excellent gloss effect.

Application

Water based ink	■
Solvent based ink	■
UV ink	■

Product Specification

Active ingredients	100 %
Density 20°C	1.13 g/cm ³
Acid value	60.0 mg KOH/g
Color	Max.10
Appearance	Clear liquid, slight yellowish to brownish

Addition levels

UNIQ® SPERSE 9330 should be dissolved in mill base diluent before the addition of pigment.

Amount of solid additive based on pigment (SOP):

- Inorganic pigments: 2 – 5 %
- Titanium dioxides: 1 – 3 %

The above recommended levels can be used for orientation and needs to be optimized by testing.

Packaging

- 25 kg
- 200 kg

Shelf life

UNIQ® SPERSE 9330 should be stored in a cool dry place. When kept in an original unopened container, it will keep up to 5 years from the date of manufacture.



UNIQ® SPERSE 9335

Block Polymeric Dispersant

UNIQ® SPERSE 9335 is a 35% active polymeric dispersant which will improve pigment dispersion and stability in water based coatings and inks.

Special Features

- Highly pigmented dispersion
- Improved particle size reduction
- Improvement in particle size stability
- Excellent viscosity stability
- Improved gloss and color strength
- Good transparency and less haze

Application

Water based ink	■
Water based digital ink	■

Product Specification

Active ingredients	35.0 %
Density 20°C	1.05 g/cm ³
Amine value	17.0 mg KOH/g
Appearance	Light brownish clear liquid

Addition levels

UNIQ® SPERSE 9335 should be dissolved in mill base diluent before the addition of pigment.

For digital inks the dosage level required could be considerably higher and dosages of 4-10mg active dispersant on weight of pigment should be considered.

For 6 mg dosage, the surface area divided by 1.66= % active dispersant on weight of pigment

Packaging

- 25 kg
- 200 kg

Shelf life

UNIQ® SPERSE 9335 should be stored in a cool dry place. When kept in an original unopened container, it will keep up to 3 years from the date of manufacture.



UNIQ® SPERSE 9370

Polymeric Dispersant

UNIQ® SPERSE 9370 is an active polymeric dispersant which will improve pigment dispersion and stability in solvent based inks.

Special Features

- Wide resin and solvent compatibility
- Improved production efficiency
- Improved pigment wetting
- Prevention of flooding and floating

Application

Solvent based ink	■
-------------------	---

Product Specification

Active ingredients	100 %
Density 20°C	0.95 g/cm ³
Amine value	80.0 mg KOH/g
Color	Max.13
Appearance	Brownish liquid

Addition levels

UNIQ® SPERSE 9370 should be dissolved in mill base diluent before the addition of pigment.

For inks the dosage level required could be considerably higher and dosages of 2mg active dispersant on weight of pigment should be considered. This is simply the surface area divided by 5.

Packaging

- 25 kg
- 190 kg

Shelf life

UNIQ® SPERSE 9370 should be stored in a cool dry place. When kept in an original unopened container, it will keep up to 5 years from the date of manufacture.

UNIQ® SPERSE 9380

Polymeric Dispersant

UNIQ® SPERSE 9380 is an active polymeric dispersant which will improve pigment dispersion and stability in solvent based inks.

Special Features

- Wide resin and solvent compatibility
- Improved production efficiency
- Improved pigment wetting
- Prevention of flooding and floating

Application

Printing inks	■
Digital inks	■

Product Specification

Active ingredients	100 %
Density 20°C	1.09 g/cm ³
Acid value	10.0 mg KOH/g
Amine value	65.0 mg KOH/g
Appearance	Light Brownish clear liquid

Addition levels

UNIQ® SPERSE 9380 should be dissolved in mill base diluent before the addition of pigment.

For digital inks the dosage level required could be considerably higher and dosages of 4-10 mg active dispersant on weight of pigment should be considered.

For 6 mg dosage, the surface area divided by 1.66=% active dispersant on weight of pigment

Packaging

- 25 kg
- 200 kg

Shelf life

UNIQ® SPERSE 9380 should be stored in a cool dry place. When kept in an original unopened container, it will keep up to 5 years from the date of manufacture.

UNIQ® SPERSE 9450

Polymeric Dispersant

UNIQ® SPERSE 9450 is an active polymeric dispersant which will improve pigment dispersion and stability in water based, solvent based and UV based inks.

Special Features

- Excellent performance in universal colorants
- Suitable for all pigments in resin free application
- Good viscosity reduction, increased pigment loading and improve production effect
- Improved gloss and tinting strength
- improved silica orientation, good in matt effect

Application

Water based ink	■
Solvent based ink	■
UV ink	■

Product Specification

Active ingredients	100 %
Density 20°C	1.05 g/cm ³
Acid Value	14.0 mg KOH/g
Amine value	3.0 mg KOH/g
Color	Max.13
Appearance	Amber to brown viscous liquid

Addition levels

UNIQ® SPERSE 9450 should be dissolved in mill base diluent before the addition of pigment.

For inks the dosage level required could be considerably higher and dosages of 2 mg active dispersant on weight of pigment should be considered. This is simply the surface area divided by 5.

Packaging

- 25 kg
- 190 kg

Shelf life

UNIQ® SPERSE 9450 should be stored in a cool dry place. When kept in an original unopened container, it will keep up to 5 years from the date of manufacture.

UNIQ[®] JET

UNIQ[®] JET 9506

Polymeric dispersant



UNIQ[®] JET 9506 is a 30% active polymeric dispersant in MPA/Butyl Acetate solvent which will improve pigment dispersion and stability in solvent based and UV based digital inks.

Special Features

- Highly pigmented dispersion
- Improved particle size reduction
- Improvements in particle size stability
- Excellent viscosity stability
- Effective in organic pigments, inorganic pigments and carbon black dispersion
- Improved gloss and color strength
- Good transparency and less haze

Application

Solvent based ink	■
Solvent based digital ink	■

Product Specification

Solvent	PMA/Butyl Acetate
Active ingredients	30 %
Density 20°C	0.95 g/cm ³
Amine value	8.0 mg KOH/g
Color	Max.10
Appearance	Light color liquid

Addition levels

UNIQ[®] JET 9506 should be dissolved in mill base diluent before the addition of pigment.

For digital inks the dosage level required could be considerably higher and dosages of 4-10mg active dispersant on weight of pigment should be considered.

For 6 mg dosage, the surface area divided by 1.66= % active dispersant on weight of pigment

Packaging

- 25 kg
- 190 kg

Shelf life

UNIQ[®] JET 9506 should be stored in a cool dry place. When kept in an original unopened container, it will keep up to 5 years from the date of manufacture.

UNIQ® JET 9510

Polymeric dispersant



UNIQ® JET 9510 is a polymeric dispersant which will improve pigment dispersion and stability in solvent based and UV based digital inks.

Special Features

- Highly pigmented dispersion
- Improved particle size reduction
- Improvements in particle size stability
- Excellent viscosity stability
- Improved gloss and color strength
- Good transparency and less haze

Application

Solvent based digital ink	■
Solvent based ink	■
UV ink	
UV digital ink	■
offset ink	■

Product Specification

Active ingredients	100 %
Amine value	17 mg KOH/g
Color	Max.10
Appearance	Brownish waxy solid

Addition levels

UNIQ® JET 9510 should be dissolved in mill base diluent before the addition of pigment.

For digital inks the dosage level required could be considerably higher and dosages of 4-10mg active dispersant on weight of pigment should be considered.

For 6 mg dosage, the surface area divided by 1.66= % active dispersant on weight of pigment.

Packaging

- 25 kg

Shelf life

UNIQ® JET 9510 should be stored in a cool dry place. When kept in an original unopened container, it will keep up to 5 years from the date of manufacture.

UNIQ® JET 9515

Polymeric dispersant



UNIQ® JET 9515 is a 50% active polymeric dispersant in PMA which will improve pigment dispersion and stability in solvent based digital inks.

Special Features

- Highly pigmented dispersion
- Improved particle size reduction
- Improvements in particle size stability
- Excellent viscosity stability
- Good transparency and color strength

Application

Solvent based ink	■
Solvent based digital ink	■

Product Specification

Solvent	PMA
Active ingredients	50 %
Density 20°C	0.96 g/cm ³
Amine value	17 mg KOH/g
Color	Max.10
Appearance	Light brown liquid

Addition levels

UNIQ® JET 9515 should be dissolved in mill base diluent before the addition of pigment.

For digital inks the dosage level required could be considerably higher and dosages of 4-10mg active dispersant on weight of pigment should be considered.

For 6 mg dosage, the surface area divided by 1.66= % active dispersant on weight of pigment

Packaging

- 25 kg
- 190 kg

Shelf life

UNIQ® JET 9515 should be stored in a cool dry place. When kept in an original unopened container, it will keep up to 5 years from the date of manufacture.

UNIQ® JET 9520

Polymeric dispersant



UNIQ® JET 9520 is a polymeric dispersant which will improve pigment dispersion and stability in solvent based and UV based digital inks.

Special Features

- Highly pigmented dispersion
- Excellent compatibility
- Improved particle size reduction
- Improvements in particle size stability
- Excellent viscosity stability
- Improved gloss and color strength
- Good transparency and less haze

Application

Solvent based digital ink	■
Solvent based ink	■
UV ink	
UV digital ink	■
offset ink	■

Product Specification

Active ingredients	100 %
Amine value	12 mg KOH/g
Color	Max.10
Appearance	Brownish waxy solid

Addition levels

UNIQ® JET 9520 should be dissolved in mill base diluent before the addition of pigment.

For digital inks the dosage level required could be considerably higher and dosages of 4-10mg active dispersant on weight of pigment should be considered.

For 6 mg dosage, the surface area divided by 1.66= % active dispersant on weight of pigment.

Packaging

- 25 kg

Shelf life

UNIQ® JET 9520 should be stored in a cool dry place. When kept in an original unopened container, it will keep up to 5 years from the date of manufacture.

UNIQ® JET 9525

Polymeric dispersant



UNIQ® JET 9525 is a 50% active polymeric dispersant in PMA which will improve pigment dispersion and stability in solvent based digital inks.

Special Features

- Suitable for organic and inorganic pigment dispersion
- Highly pigmented dispersion
- Improved particle size reduction
- Improvements in particle size stability
- Excellent viscosity stability
- Good transparency and color strength

Application

Solvent based ink	■
Solvent based digital ink	■

Product Specification

Solvent	PMA
Active ingredients	50 %
Density 20°C	0.96 g/cm ³
Color	Max. 13
Appearance	Light brown liquid

Addition levels

UNIQ® JET 9525 should be dissolved in mill base diluent before the addition of pigment.

For digital inks the dosage level required could be considerably higher and dosages of 4-10mg active dispersant on weight of pigment should be considered.

For 6 mg dosage, the surface area divided by 1.66= % active dispersant on weight of pigment

Packaging

- 25 kg
- 190 kg

Shelf life

UNIQ® JET 9525 should be stored in a cool dry place. When kept in an original unopened container, it will keep up to 5 years from the date of manufacture.

UNIQ® JET 9530

Polymeric dispersant



UNIQ® JET 9530 is a polymeric dispersant which will improve pigment dispersion and stability in solvent based and UV based digital inks.

Special Features

- Highly pigmented dispersion
- Improved particle size reduction
- Improvements in particle size stability
- Excellent viscosity stability
- Improved gloss and color strength
- Good transparency and less haze

Application

Solvent based digital ink	■
UV ink	
UV digital ink	■
offset ink	■

Product Specification

Active ingredients	100 %
Density 20°C	1.06 g/cm ³
Amine value	45 mg KOH/g
Acid value	13 mg KOH/g
Color	Max. 10
Appearance	Brown liquid

Addition levels

UNIQ® JET 9530 should be dissolved in mill base diluent before the addition of pigment.

For digital inks the dosage level required could be considerably higher and dosages of 4-10mg active dispersant on weight of pigment should be considered.

For 6 mg dosage, the surface area divided by 1.66= % active dispersant on weight of pigment.

Packaging

- 25 kg
- 190 kg

Shelf life

UNIQ® JET 9530 should be stored in a cool dry place. When kept in an original unopened container, it will keep up to 5 years from the date of manufacture.

UNIQ® JET 9550

Polymeric dispersant



UNIQ® JET 9550 is a polymeric dispersant which will improve pigment dispersion and stability in solvent based and UV based digital inks.

Special Features

- Highly pigmented dispersion
- Improved particle size reduction
- Improvements in particle size stability
- Excellent viscosity stability
- Improved gloss and color strength
- Good transparency and less haze

Application

Solvent based digital ink	■
UV ink	
UV digital ink	■
offset ink	■

Product Specification

Active ingredients	100 %
Density 20°C	1.1 g/cm ³
Amine value	75 mg KOH/g
Acid value	11mg KOH/g
Appearance	Light brownish liquid

Addition levels

UNIQ® JET 9550 should be dissolved in mill base diluent before the addition of pigment.

For digital inks the dosage level required could be considerably higher and dosages of 4-10mg active dispersant on weight of pigment should be considered.

For 6 mg dosage, the surface area divided by 1.66= % active dispersant on weight of pigment.

Packaging

- 25 kg

Shelf life

UNIQ® JET 9550 should be stored in a cool dry place. When kept in an original unopened container, it will keep up to 3 years from the date of manufacture.

UNIQ® JET 9560

Polymeric dispersant



UNIQ® JET 9560 is a polymeric dispersant which will improve pigment dispersion and stability in solvent-, water-based and UV digital inks.

UNIQ® JET 9053

Polymeric dispersant



UNIQ® JET 9053 is a polymeric dispersant which will improve pigment dispersion and stability in solvent based and UV based inks.

Special Features

- Excellent dispersant for inorganic and organic pigments, especially for high performance organic pigments
- Improvements in particle size stability
- Excellent viscosity stability
- Improved gloss and color strength
- Good transparency and gloss
- Suited for resin free pigment concentrates

Application

Solvent based digital ink	■
Water based digital ink	■
UV ink	
UV digital ink	■
offset ink	■

Special Features

- Suitable for resin containing and resin free pigment dispersion
- Excellent pigment wetting property
- Efficient viscosity reduction, improved pigment loading
- Good pigment paste stability
- Improved color strength and high gloss

Application

Solvent based ink	■
Water based ink	■
UV ink	■

Product Specification

Active ingredients	100 %
Density 20°C	1.06 g/cm ³
Amine value	50 mg KOH/g
Appearance	Brownish liquid

Addition levels

UNIQ® JET 9560 should be dissolved in mill base diluent before the addition of pigment.

For digital inks the dosage level required could be considerably higher and dosages of 4-10mg active dispersant on weight of pigment should be considered.

For 6 mg dosage, the surface area divided by 1.66= % active dispersant on weight of pigment

Product Specification

Active ingredients	100 %
Density 20°C	1.1 g/cm ³
Acid Value	12.0 mg KOH/g
Color	Max.8
Appearance	Brownish clear liquid

Addition levels

UNIQ® JET 9053 should be dissolved in mill base diluent before the addition of pigment.

For digital inks the dosage level required could be considerably higher and dosages of 4-10mg active dispersant on weight of pigment should be considered.

For 6 mg dosage, the surface area divided by 1.66= % active dispersant on weight of pigment

Packaging

- 25 kg

Shelf life

UNIQ® JET 9560 should be stored in a cool dry place. When kept in an original unopened container, it will keep up to 5 years from the date of manufacture.

Packaging

- 25 kg
- 200 kg

Shelf life

UNIQ® JET 9053 should be stored in a cool dry place. When kept in an original unopened container, it will keep up to 5 years from the date of manufacture.

Additives for Plastic industrie

- PVC Plastisols
- Putty
- SMC/BMC
- Composites
- Liquid masterbatches



UNIQ® FOAM P-509

Solution of silicone free defoaming polymers

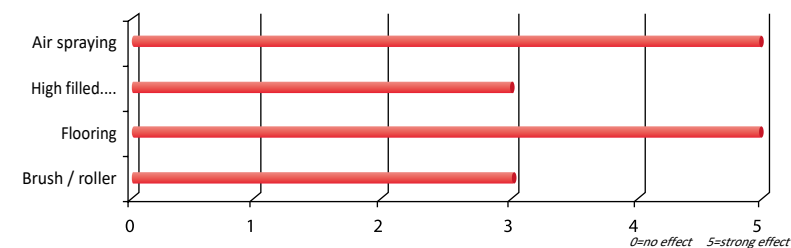

UNIQ® FOAM P-509 is a strong anti-foam and air-release agent especially suitable for ambient-curing plastic systems. Especially suitable for unsaturated polyesters and epoxy based systems.

Special Features

- Quick de-aeration and defoaming effect
- Foam reduction during production
- Suitable for pigment loaded systems
- Silicone-free
- Heat stable

Application

Ambient curing plastic	<input type="checkbox"/>
UPE	<input checked="" type="checkbox"/>
Epoxy	<input checked="" type="checkbox"/>

highly recommended ■
recommended □

Product Specification

Density 20°C	1.05 g/cm ³
Color	Max. 3
Appearance	Clear colorless liquid

Addition levels

- Based on total formulation: 0.1 – 1.0 %

Ensure good distribution to avoid surface defects.

Although the product may be slightly turbid, this cannot be observed anymore in the final dry film.

Packaging

- 25 kg
- 200 kg

Shelf life

UNIQ® FOAM P-509 should be stored in a cool dry place. When kept in an original unopened container, it will keep up to 5 years from the date of manufacture.



UNIQ® FOAM P-540

Solution of non-silicone polymers



UNIQ® FOAM

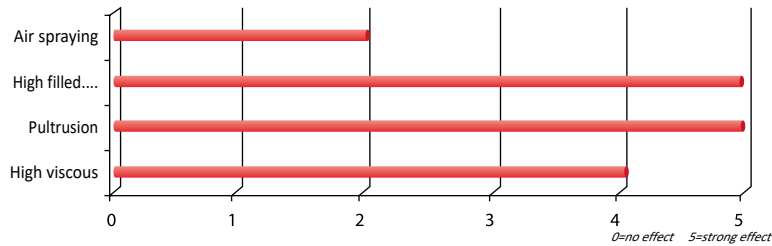

UNIQ® FOAM P-540 is a silicone-free anti-foam and air-release agent and furthermore helps to improve the leveling and avoids pinholing or popping. It's suitable for unsaturated polyester systems, gel coats and cast resins. It is also recommended for pultrusion applications with acrylic, unsaturated polyester and vinyl ester resins.

Special Features

- Quick de-aeration and defoaming effect
- Excellent fiber wetting properties
- May cause haze in the finished part in some resins
- Silicone-free
- Heat stable

Application

Ambient curing plastic UPE	■
Pultrusion application Acrylic UPE Vinyl ester resin	■ ■ ■

highly recommended ■
recommended □

Product Specification

Density 20°C	0.82 g/cm ³
Refractive index	1.4435
Appearance	Clear colorless liquid

Addition levels

- Based on total formulation: 0.1 – 1.0 %

Ensure good distribution to avoid surface defects.

Although the product may be slightly turbid, this cannot be observed anymore in the final dry film.

Packaging

- 20 kg
- 160 kg

Shelf life

UNIQ® FOAM P-540 should be stored in a cool dry place. When kept in an original unopened container, it will keep up to 5 years from the date of manufacture.

UNIQ® FOAM P-555

Solution of Silicone free polymers

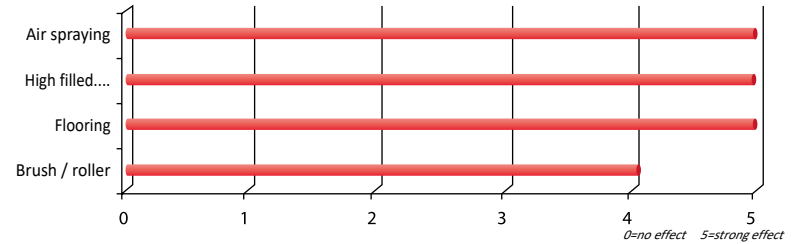

UNIQ® FOAM P-555 is a strong anti-foam and air-release agent especially suitable for ambient-curing plastic systems, adhesives and sealants. Especially suitable for unsaturated polyesters.

Special Features

- Quick de-aeration and defoaming effect for pigmented and non pigmented solvent free coating system
- Does not interfere intercoat adhesion
- Excellent film appearances
- Silicone-free
- Heat stable

Application

Pultrusion of plastic systems UPE Acrylates Vinyl esters	■ ■ ■
Ambient curing systems	■
PVC Plastisols	■

highly recommended ■
recommended □

Product Specification

Density 20°C	0.91 g/cm ³
Color	Max. 1
Appearance	Slight hazy colorless liquid

Addition levels

- Based on total formulation: 0.1 – 1.0 %

Can be added in any stage of the formulation.

Although the product may be slightly turbid, this cannot be observed anymore in the final dry film.

Packaging

- 22 kg
- 170 kg

Shelf life

UNIQ® FOAM P-555 should be stored in a cool dry place. When kept in an original unopened container, it will keep up to 5 years from the date of manufacture.

UNIQ[®] FOAM P-570

Solution of defoaming polymers and polysiloxanes



UNIQ[®] FOAM

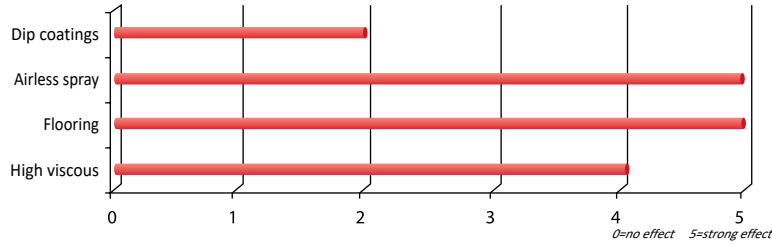

UNIQ[®] FOAM P-570 is a strong anti-foam and air-release agent especially suitable for ambient-curing plastic systems, adhesives and sealants and coating industry. Especially suitable for epoxy based systems.

UNIQ[®] FOAM P-571

Silicone free defoamer of solution polymers

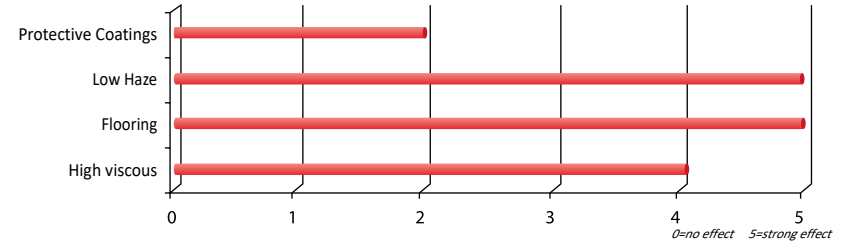

UNIQ[®] FOAM P-571 is a strong anti-foam and air-release agent especially suitable for ambient-curing plastic systems, adhesives and sealants and coating industry. Especially suitable for epoxy based systems, UPE and PVC plastisols.

Special Features

- Quick de-aeration and defoaming effect
- Foam reduction during manufacturing
- Suited for pigmented systems
- Can cause turbidity in clear systems

Application

Pultrusion of plastic systems Epoxy based	■
Ambient curing plastic Epoxy based	■

Special Features

- Quick de-aeration and defoaming effect
- Silicone free
- Foam reduction during manufacturing
- Suited for pigmented systems
- Can cause turbidity in clear systems

Application

Pultrusion of plastic systems UPE Epoxy PU	■ ■ ■
Ambient curing systems	■
PVC Plastisols	■

highly recommended ■
recommended □

Product Specification

Density 20°C	0.81 g/cm ³
Color	Max. 3
Appearance	Slight hazy colorless liquid

Addition levels

- Based on total formulation: 0.1 – 1.0 %

Can be added in any stage of the formulation.

Although the product may be slightly turbid, this cannot be observed anymore in the final dry film.

Product Specification

Density 20°C	0.81 g/cm ³
Appearance	Colorless clear liquid

Addition levels

- Based on total formulation: 0.1 – 1.0 %

Can be added in any stage of the formulation.

Although the product may be slightly turbid, this cannot be observed anymore in the final dry film.

Packaging

- 22 kg
- 170 kg

Shelf life

UNIQ[®] FOAM P-570 should be stored in a cool dry place. When kept in an original unopened container, it will keep up to 5 years from the date of manufacture.

Packaging

- 22 kg
- 170 kg

Shelf life

UNIQ[®] FOAM P-571 should be stored in a cool dry place. When kept in an original unopened container, it will keep up to 5 years from the date of manufacture.

UNIQ® FOAM P-575

Solution of non-silicone defoaming polymers

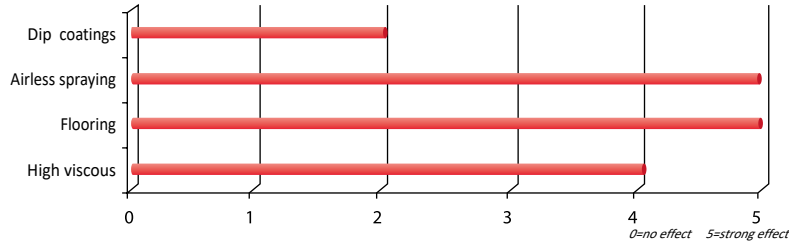

UNIQ® FOAM P-575 is a strong anti-foam and air-release agent especially suitable for ambient-curing plastic systems, adhesives and sealants and coating industry, especially for epoxy and PU based resin systems. The additive furthermore helps to improve the leveling and avoids pinholing or popping.

UNIQ® FOAM P-595

Solution of non-silicone defoaming polymers

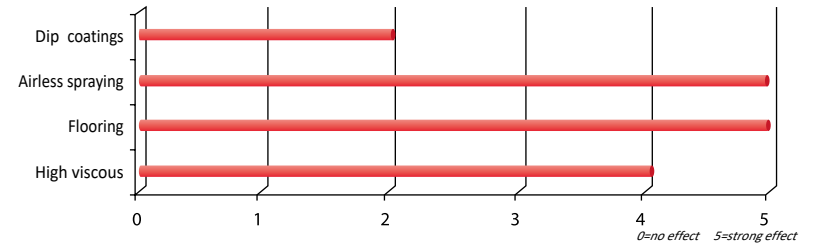

UNIQ® FOAM P-595 is a strong anti-foam and air-release agent especially suitable for ambient-curing plastic systems, adhesives and sealants and coating industry, especially for epoxy and PU based resin systems. The additive furthermore helps to improve the leveling and avoids pinholing or popping.

Special Features

- Quick de-aeration and defoaming effect
- Foam reduction during manufacturing
- Suited for pigmented systems
- Can cause turbidity in clear systems
- Silicone free
- Heat stable

Application

Adhesives and sealants Epoxy based PU based	■ ■
Ambient curing plastic Epoxy based PU based	■ ■

highly recommended ■
recommended □

Special Features

- Quick de-aeration and defoaming effect
- Suited for pigmented and non pigmented systems
- Silicone free
- Heat stable

Application

Adhesives and sealants Epoxy based PU based	■ ■
Ambient curing plastic Epoxy based PU based	■ ■

highly recommended ■
recommended □

Product Specification

Density 20°C	0.96 g/cm ³
Color	Max. 3
Appearance	Slight hazy liquid

Addition levels

- Based on total formulation: 0.1 – 1.0 %

Can be added in any stage of the formulation.

Although the product may be slightly turbid, this cannot be observed anymore in the final dry film.

Product Specification

Density 20°C	0.83 g/cm ³
Color	Max. 1
Appearance	Slight hazy liquid

Addition levels

- Based on total formulation: 0.1 – 1.0 %

Can be added in any stage of the formulation.

Although the product may be slightly turbid, this cannot be observed anymore in the final dry film.

Packaging

- 22 kg
- 170 kg

Shelf life

UNIQ® FOAM P-575 should be stored in a cool dry place. When kept in an original unopened container, it will keep up to 5 years from the date of manufacture.

Packaging

- 22 kg
- 170 kg

Shelf life

UNIQ® FOAM P-595 should be stored in a cool dry place. When kept in an original unopened container, it will keep up to 5 years from the date of manufacture.

UNIQ[®] FLOW P-304

Polymeric leveling agent with defoaming performance

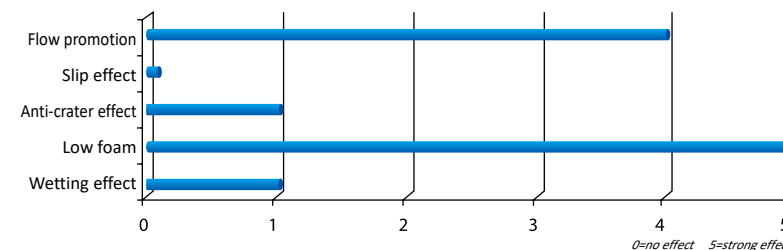

UNIQ[®] FLOW P-304 is a cost effective acrylic leveling agent for solvent based and solvent free systems. It's very suitable for gel coats that are base on unsaturated polyesters, epoxides and polyurethanes. The product shows excellent defoaming and leveling performances. It is non-silicone and therefore will not cause intercoat adhesion problems.

The additive is preferably used in combination with air release agent like **UNIQ[®] FOAM P-555**.

Special Features

- Solvent borne and solvent free applications
- Improves levelling
- Acts as a defoamer and de-aeration aid
- Does not interfere intercoat adhesion
- Silicone free
- Heat stable

Application

Ambient curing systems	
UPE	■
Epoxy	■
PU	■
Adhesives and sealants	
UPE	■
Epoxy	■
PU	■

highly recommended ■
recommended □

Product Specification

Active ingredients	100 %
Density	1.00 g/cm ³
Color	Max. 1
Appearance	Transparent viscous liquid

Addition levels

- Based on total formulation: 0.1 – 1.0 %

The above recommended levels can be used for orientation and needs to be optimized by testing.

Packaging

- 25 kg
- 190 kg

Shelf life

UNIQ[®] FLOW P-304 should be stored in a cool dry place. When kept in an original unopened container, it will keep up to 5 years from the date of manufacture.

UNIQ® SPERSE P-114

Wetting and dispersing additive for filled unsaturated polyesters

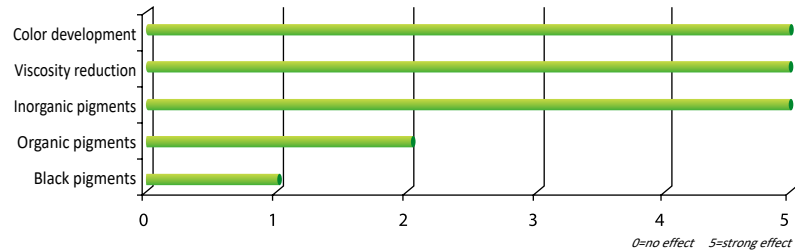

UNIQ® SPERSE P-114 is a wetting and dispersing additive for filled unsaturated polyester eg calcium carbonate and ATH. Strong viscosities reduction so higher pigment and filler loading in the grinding process can be achieved.

In BMC the **UNIQ® SPERSE P-114** is used as viscosity stabilizer

Special Features

- Wetting and dispersing agent for TiO₂, inorganic pigments and fillers
- Reduce the viscosity
- increase the pigment and filler loading

Application

LP and Class A formulations	■
LS formulations	■
Pultrusion	■
Epoxy systems	■
Viscosity stabilization BMC	■

highly recommended ■
recommended □

Product Specification

Active ingredients	51 %
Density 20°C	1.01 g/cm ³
Acid Value	64 mg KOH/g
Solvent	PMA/Hydrocarbons C9 aromatics
Appearance	Light yellowish transparent liquid

Addition levels

Amount of solid additive based on pigment (SOP):

- Fillers/pigments: 0.5 - 1%
- BMC: 0.25 - 1%

The above recommended levels can be used for orientation and needs to be optimized by testing.

Packaging

- 25 kg
- 190 kg

Shelf life

UNIQ® SPERSE P-114 should be stored in a cool dry place. When kept in an original unopened container, it will keep up to 5 years from the date of manufacture.

UNIQ® SPERSE P-120

Wetting and dispersing additive for filled unsaturated polyesters

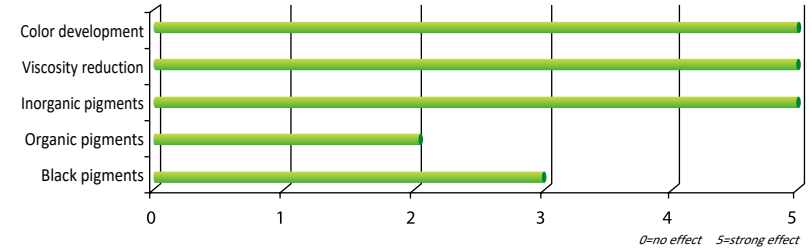

UNIQ® SPERSE P-120 is a wetting and dispersing additive for filled unsaturated polyester, acrylic and epoxy resins to reduce the viscosity and prevent settling. Strong viscosities reduction so higher pigment and filler loading in the grinding process can be achieved. For fiber-reinforced spray up and hand lay-up resins.

Special Features

- Solvent based applications
- Wetting and dispersing agent for TiO₂, inorganic pigments and fillers
- Reduce the viscosity
- increase the pigment and filler loading
- Excellent wetting

Application

Ambient curing systems	
UPE	■
Acrylic	■
Epoxy	■
Adhesives and sealants	
Epoxy	■
Acrylic	■
PU	■

highly recommended ■
recommended □

Product Specification

Active ingredients	80 %
Solvent	BG
Density 20°C	0.97 g/cm ³
Acid value	39 mg KOH/g
Amine value	31 mg KOH/g
Color	Max.11
Appearance	Brownish clear liquid

Addition levels

Amount of solid additive based on pigment (SOP):

- Fillers/pigments: 0.5 – 1.5%

The above recommended levels can be used for orientation and needs to be optimized by testing.

Packaging

- 22 kg
- 180 kg

Shelf life

UNIQ® SPERSE P-120 should be stored in a cool dry place. When kept in an original unopened container, it will keep up to 5 years from the date of manufacture.

UNIQ® SPERSE P-134

Polymeric wetting and dispersing additive

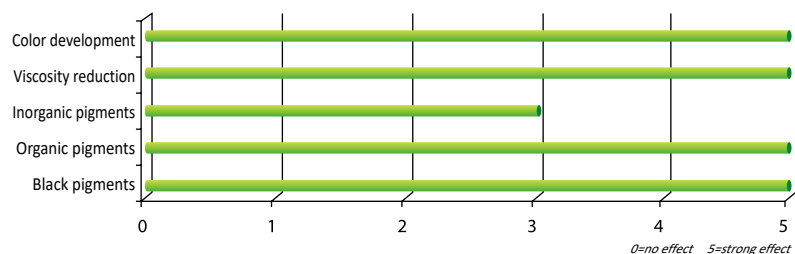

UNIQ® SPERSE P-134 is a solvent-free wetting and dispersing additive, very suitable for solvent-borne and solvent-free adhesives, PVC plastisol, ambient curing resin systems, and for the production of color master batches for thermoplastics. Particularly recommended for carbon black pigments. And it can also prevent separation and improve the fiber wetting in SMC/BMC formulations.

Special Features

- Solvent-borne and solvent-free applications
- Wetting and dispersing agent for organic pigments, especially for carbon black
- Reduce the viscosity
- Increase the pigment loading
- High gloss
- Good transparency for transparent pigments and good hiding power for opaque pigments

Application

Adhesives	■
PVC Plastisols	■
SMC/BMC	■
Pultrusion	■
Ambient curing systems	■
Thermoplastics	■

highly recommended ■
recommended □

Product Specification

Active ingredients	100 %
Density 20°C	1.05 g/cm ³
Acid value	15 mg KOH/g
Amine value	35 mg KOH/g
Appearance	Brownish clear liquid

Addition levels

Amount of solid additive based on pigment (SOP):

- Titanium dioxides: 1 - 3%
- Inorganic pigments: 5 - 10%
- Organic pigments: 10 - 25%
- Carbon black: 15 - 50%

The above recommended levels can be used for orientation and need to be optimized by testing

Packaging

- 25 kg
- 200 kg

Shelf life

UNIQ® SPERSE P-134 should be stored in a cool dry place. When kept in an original unopened container, it will keep up to 5 years from the date of manufacture.

UNIQ® SPERSE P-135

Polymeric wetting and dispersing additive

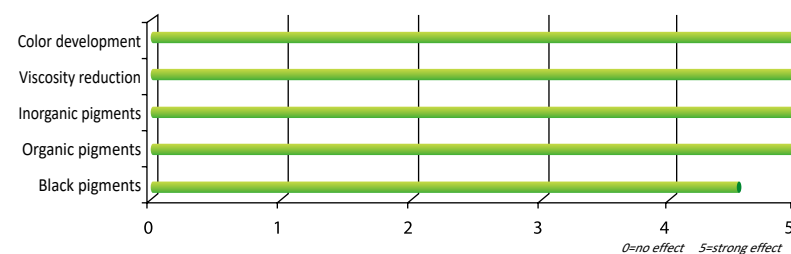

UNIQ® SPERSE P-135 is a solvent-free wetting and dispersing additive, very suitable for solvent-borne and solvent-free adhesives, PVC plastisol, ambient curing resin systems, and for the production of liquid color masterbatches for thermoplastics. Particularly recommended for organic pigments and carbon black. And it's also suitable for epoxy flooring and gel coats system. It gives excellent anti floating and flooding performance

Special Features

- Solvent-borne and solvent-free applications
- Suited for organic and inorganic pigments, especially for carbon black
- Strong viscosity reduction
- High transparency and gloss
- Improve the color strength
- Excellent anti floating and flooding performance

Application

Adhesives	■
PVC Plastisols	■
Pultrusion	■
Ambient curing systems	■
Thermoplastics	■
Epoxy flooring	■
Gel coats	■

highly recommended ■
recommended □

Product Specification

Active ingredients	100 %
Density 20°C	1.08 g/cm ³
Acid value	10.0 mg KOH/g
Amine value	66.0 mg KOH/g
Appearance	Light brownish clear liquid

Addition levels

Amount of solid additive based on pigment (SOP):

- Titanium dioxides: 2 - 5%
- Inorganic pigments: 2 - 5%
- Organic pigments: 15 - 50%
- Carbon black: 20 - 80%

The above recommended levels can be used for orientation and need to be optimized by testing

Packaging

- 25 kg
- 200 kg

Shelf life

UNIQ® SPERSE P-135 should be stored in a cool dry place. When kept in an original unopened container, it will keep up to 5 years from the date of manufacture.

UNIQ® SPERSE P-136

Polymeric wetting and dispersing additive

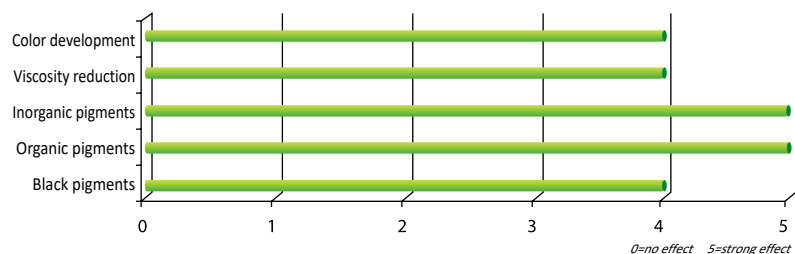

UNIQ® SPERSE P-136 is a wetting and dispersing additive for inorganic pigments, organic pigments and carbon black in adhesive, plastisols, ambient curing resin systems, and for the production of color pastes for thermoplastics. It is also very suitable for SMC/BMC and pultrusion to homogenize and stabilize the system, and to increase the color homogeneity in molding compounds; and it can give good fiber wetting and anti-separation performance.

Special Features

- Wetting and dispersing agent for inorganic-, organic- and carbon black pigments
- Reduce the viscosity
- improve the color strength
- Anti-separation agent
- Fiber wetting

Application

Adhesives	■
Plastisols	■
SMC/BC	■
Pultrusion	■
Ambient curing resin systems	■
Thermoplastics	■

highly recommended ■
recommended □

Product Specification

Active ingredients	45 %
Solvents	Butylacetate/PMA
Density 20°C	1.00 g/cm ³
Amine value	14 mg KOH/g
Color	Max 10
Appearance	Brownish clear liquid

Addition levels

Amount of solid additive based on pigment (SOP):

- Titanium dioxides: 1 - 3%
- Inorganic pigments: 2 - 5%
- Organic pigments: 15 - 30%
- Carbon black: 20 - 50%

The above recommended levels can be used for orientation and needs to be optimized by testing

Packaging

- 25 kg
- 190 kg

Shelf life

UNIQ® SPERSE P-136 should be stored in a cool dry place. When kept in an original unopened container, it will keep up to 5 years from the date of manufacture.

UNIQ® SPERSE P-138

Polymeric wetting and dispersing additive

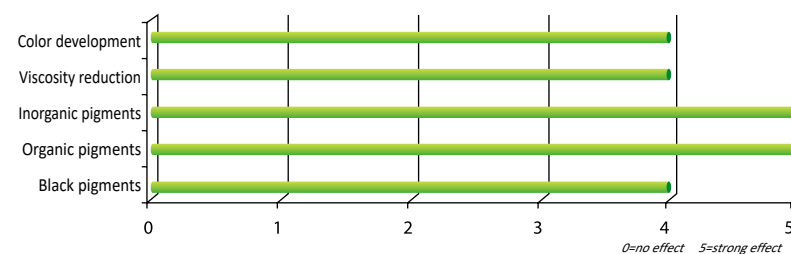

UNIQ® SPERSE P-138 is a wetting and dispersing additive for inorganic pigments, organic pigments and carbon black in adhesive, plastisols, ambient curing resin systems, and for the production of color pastes for thermoplastics. It is also very suitable for SMC/BMC and pultrusion to homogenize and stabilize the system, and to increase the color homogeneity in molding compounds; and it can give good fiber wetting and anti-separation performance.

Special Features

- Wetting and dispersing agent for inorganic-, organic pigments and carbon black
- Improve the color strength
- Anti-separation performance
- Fiber wetting

Application

Adhesives	■
Plastisols	■
SMC/BC	■
Pultrusion	■
Ambient curing resin systems	■
Thermoplastics	■

highly recommended ■
recommended □

Product Specification

Active ingredients	30 %
Solvent	Butylacetate/PMA/Xylene
Density 20°C	0.95 g/cm ³
Amine value	8.0 mg KOH/g
Color	Max. 6
Appearance	Brownish clear liquid

Addition levels

Addition level as supplied:

- Titanium dioxides: 1 - 3%
- Inorganic pigments: 2 - 5%
- Organic pigments: 15 - 30%
- Carbon black: 20 - 50%
- Prevents phase separation (on resin): 0.5 - 1%
- Fiber wetting (based on fiber): 0.5 - 1%

The above recommended levels can be used for orientation and needs to be optimized by testing

Packaging

- 25 kg
- 190 kg

Shelf life

UNIQ® SPERSE P-138 should be stored in a cool dry place. When kept in an original unopened container, it will keep up to 5 years from the date of manufacture.

UNIQ® SPERSE P-141

Wetting and dispersing additive

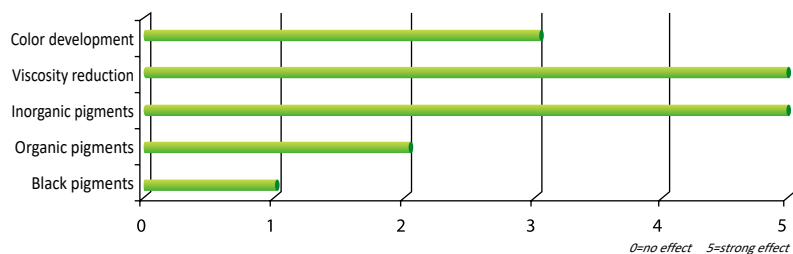

UNIQ® SPERSE P-141 is a wetting and dispersing additive for amine-accelerated UP, EP and, PUR systems and adhesives to reduce the viscosity in mineral-filled systems. Strong viscosities reduction so higher pigment and filler loading in the grinding process can be achieved. Due to its OH- functionality, this additive is incorporated into the polymer matrix and is therefore suitable for systems in which fogging and emissions are critical.

UNIQ® SPERSE P-144

Wetting and dispersing additive for filled unsaturated polyesters

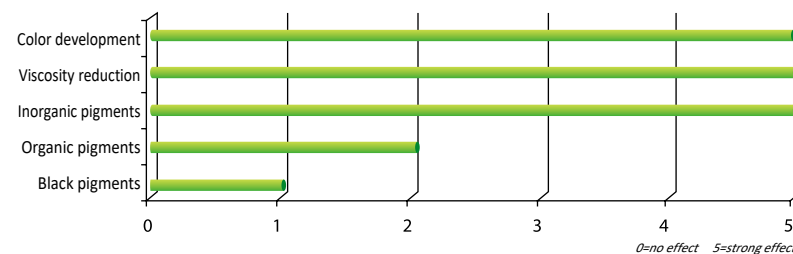

UNIQ® SPERSE P-144 is a wetting and dispersing additive for filled unsaturated polyester, acrylic and epoxy resins to reduce the viscosity and prevent settling. Strong viscosities reduction so higher pigment and filler loading in the grinding process can be achieved. For fiber-reinforced spray up and hand lay-up resins.

UNIQ® SPERSE

Special Features

- Wetting and dispersing agent for TiO₂, inorganic pigments and fillers
- Reduce the viscosity
- increase the pigment and filler loading
- Excellent wetting

Application

Ambient curing systems	
UPE	■
Acrylic	■
Epoxy	■
PU	■
Adhesives and sealants	
Epoxy	■
Acrylic	■
PU	■

■ highly recommended
□ recommended

Special Features

- Solvent based applications
- Wetting and dispersing agent for TiO₂, inorganic pigments and fillers
- Reduce the viscosity
- increase the pigment and filler loading
- excellent wetting

Application

Ambient curing systems	
UPE	■
Acrylic	■
Epoxy	■
Adhesives and sealants	
Epoxy	■
Acrylic	■
PU	■

■ highly recommended
□ recommended

Product Specification

Active ingredients	50 %
Solvent	EPH
Density 20°C	1.12 g/cm ³
Acid value	66 mg KOH/g
Appearance	Brownish clear liquid

Addition levels

Amount of solid additive based on pigment (SOP):

- Fillers/pigments: 0.5 – 2.0%

The above recommended levels can be used for orientation and needs to be optimized by testing.

Product Specification

Active ingredients	50 %
Density 20°C	0.86 g/cm ³
Acid value	35 mg KOH/g
Amine value	20 mg KOH/g
Appearance	Brownish clear liquid

Addition levels

Amount of solid additive based on pigment (SOP):

- Fillers/pigments: 0.5 – 2.0%

The above recommended levels can be used for orientation and needs to be optimized by testing.

Packaging

- 25 kg
- 200 kg

Shelf life

UNIQ® SPERSE P-141 should be stored in a cool dry place. When kept in an original unopened container, it will keep up to 5 years from the date of manufacture.

Packaging

- 22 kg
- 170 kg

Shelf life

UNIQ® SPERSE P-144 should be stored in a cool dry place. When kept in an original unopened container, it will keep up to 5 years from the date of manufacture.

UNIQ® SPERSE P-145

Processing additive with mold release properties



UNIQ® SPERSE P-145 is a processing additive with mold release properties for low-shrink SMC and BMC. The zinc stearate that is usually used as a mold release agent is completely replaced by the additive, which can simplify raw material handling. The most important property is the anti-separation of the LS-SMC/BMC compounds and thus cobwebbing is reduced. Scrap rate is lowered due to reduced shrinkage and less warping. At the same time, the additive gives higher gloss, lower haze and improves color homogeneity. You can gain generally higher surface appearance of the finished parts.

If the finished parts are to be painted or bonded, no sanding is required, as UNIQ® SPERSE P-145 is firmly anchored in the cured resin and does not migrate to the surface. Due to the low dosage of the additive, it is virtually cost neutral.

UNIQ® SPERSE P-160

W&D agent with silicone to prevent flooding and floating of pigments

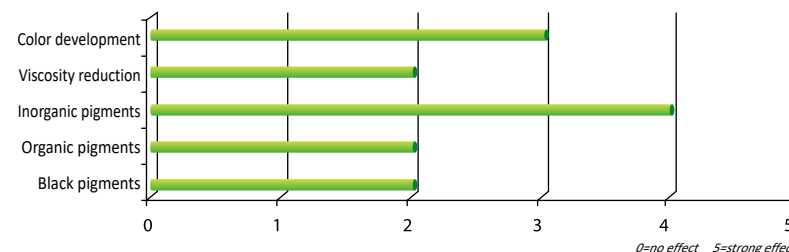

UNIQ® SPERSE P-160 is a wetting and dispersing additive in unsaturated resin systems and adhesives. The additive prevents the flooding/floating and settling of pigments and fillers in epoxy and VE/UP-based laminates. Reduction in the flooding/floating of colored pigments in gel coats.

UNIQ® SPERSE

Special Features

- Processing additive for low-shrink SMC and BMC
- Excellent mold release properties
- Anti-separation of the LS-SMC/BMC compounds, reducing the cobwebbing
- Decreasing the haze
- Improving the gloss

Application

SMC (LS)	■
BMC /DMC	□

highly recommended ■
recommended □

Special Features

- Prevention of flooding and floating
- Reduce dispersion time
- Reduce tendency of Bernard cells
- Stabilization of the pigment dispersion
- Decrease pigment sedimentation

Application

Ambient curing systems Vinyl / UPE Epoxy	■ ■
Adhesives and sealants Vinyl / UPE Epoxy	■ ■
Pultrusion Vinyl/UPE	■

highly recommended ■
recommended □

Product Specification

Active ingredients	100 %
Density 20°C	0.94 g/cm ³
Flash point	> 100°C
Appearance	Slight brownish liquid

Addition levels

Amount of solid additive based on resin:

- Total resin: 2 – 2.5%
- Highly filled systems: 2 – 4%

The above recommended levels can be used for orientation and needs to be optimized by testing.

Product Specification

Active ingredients	50 %
Solvent	Hydrocarbons C9 aromatics/Xylene/MIBK
Density 20°C	0.95 g/cm ³
Acid value	125 mg KOH/g
Color	Max. 12
Appearance	Brownish liquid

Addition levels

Amount of solid additive based on pigment (SOP):

- Inorganic pigments: 0.5 – 3 %
- Titanium dioxides: 0.2 – 2 %
- Organic pigments: 2 – 5 %
- Fillers: 0.5 – 2 %

The above recommended levels can be used for orientation and needs to be optimized by testing.

Packaging

- 22 kg

Shelf life

UNIQ® SPERSE P-145 should be stored in a cool dry place. When kept in an original unopened container, it will keep up to 5 years from the date of manufacture.

Packaging

- 25 kg
- 180 kg

Shelf life

UNIQ® SPERSE P-160 should be stored in a cool dry place. When kept in an original unopened container, it will keep up to 5 years from the date of manufacture.

UNIQ® SPERSE P-185

Polymeric dispersant

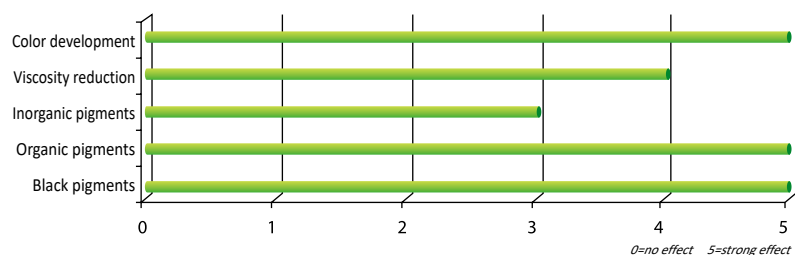

UNIQ® SPERSE P-185 is a solvent-free wetting and dispersing additive, very suitable for solvent-borne and solvent-free adhesives, PVC plastisols, ambient curing resin systems, and for the production of color masterbatches for thermoplastics. Particularly recommended for organic pigments, inorganic pigments and carbon black. And it's also suitable for epoxy flooring system.

Special Features

- Solvent-borne and solve-free applications
- Wetting and dispersing agent for organic and inorganic pigments, especially for carbon black
- Improve the color strength
- Increase the pigment loading
- Protect color floatation
- High gloss

Application

Adhesives	■
PVC Plastisols	■
SMC/BMC	■
Pultrusion	■
Ambient curing systems	■
Thermoplastics	■
Epoxy flooring	■

highly recommended ■
recommended □

Product Specification

Active ingredients	100 %
Density 20°C	1.10 g/cm ³
Acid value	12 mg KOH/g
Amine value	5 mg KOH/g
Color	Max.8
Appearance	Brownish clear liquid

Addition levels

Amount of solid additive based on pigment (SOP):

- Titanium dioxides: 1 - 3%
- Inorganic pigments: 2 - 5%
- Organic pigments: 15 - 50%
- Carbon black: 20 - 80%

The above recommended levels can be used for orientation and needs to be optimized by testing

Packaging

- 25 kg
- 200 kg

Shelf life

UNIQ® SPERSE P-185 should be stored in a cool dry place. When kept in an original unopened container, it will keep up to 5 years from the date of manufacture.

UNIQ® SPERSE P-190

Wetting and dispersing additive for filled unsaturated polyesters

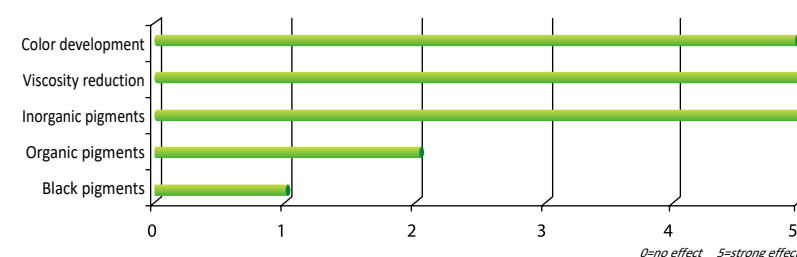

UNIQ® SPERSE P-190 is a wetting and dispersing additive for filled unsaturated polyester. The dispersant is especially suitable for inorganic pigments and filler pigments. Strong viscosities reduction so higher pigment and filler loading in the grinding process can be achieved.

Special Features

- Solvent based applications
- Wetting and dispersing agent for TiO₂, inorganic pigments and fillers
- Reduce the viscosity
- increase the pigment and filler loading
- Prevents color floating when mixed with tinters

Application

Low emission SMC/BMC X	■
LP and Class A formulations X	■
LS formulations X	■
Pultrusion X	■
Viscosity stabilizer	■

highly recommended ■
recommended □

Product Specification

Active ingredients	100 %
Density 20°C	1.10 g/cm ³
Acid value	110.0 mg KOH/g
Amine value	10.0 mg KOH/g
Appearance	Brownish sticky liquid

Addition levels

Amount of solid additive based on pigment (SOP):

- Fillers: 0.5 - 1%
- Titanium dioxides: 1 - 2%

The above recommended levels can be used for orientation and needs to be optimized by testing

Packaging

- 25 kg
- 200 kg

Shelf life

UNIQ® SPERSE P-190 should be stored in a cool dry place. When kept in an original unopened container, it will keep up to 5 years from the date of manufacture.

UNIQ® SPERSE P-191

Wetting and dispersing additive for filled unsaturated polyesters

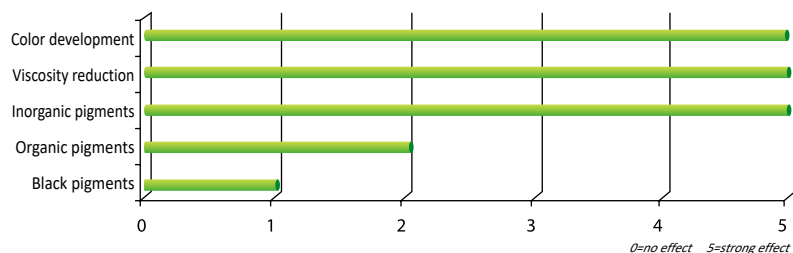

UNIQ® SPERSE P-191 is a wetting and dispersing additive for filled unsaturated polyester. The dispersant is especially suitable for inorganic pigments and filler pigments. Strong viscosities reduction so higher pigment and filler loading in the grinding process can be achieved.

Special Features

- Wetting and dispersing agent for TiO₂, inorganic pigments and fillers
- Reduce the viscosity
- increase the pigment and filler loading

Application

Low emission SMC/BMC X	■
LP and Class A formulations X	■
LS formulations X	■
Pultrusion X	■
Viscosity stabilizer	■

highly recommended ■
recommended □

Product Specification

Active ingredients	100 %
Density 20°C	1.07 g/cm ³
Acid value	140 mg KOH/g
Color	Max. 5
Appearance	Slight yellowish clear liquid

Addition levels

Amount of solid additive based on pigment (SOP):

- Fillers: 0.5 - 1%
- Titanium dioxides: 1 - 2%

The above recommended levels can be used for orientation and needs to be optimized by testing

Packaging

- 25 kg
- 200 kg

Shelf life

UNIQ® SPERSE P-191 should be stored in a cool dry place. When kept in an original unopened container, it will keep up to 5 years from the date of manufacture.

UNIQ® SPERSE P-193

Wetting and dispersing additive for filled unsaturated polyesters

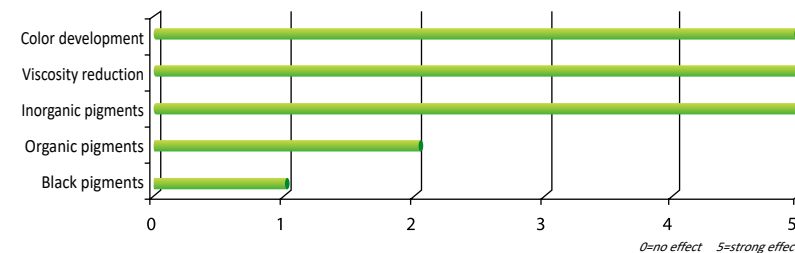

UNIQ® SPERSE P-193 is a wetting and dispersing additive for filled unsaturated polyester, epoxy systems, PVS plastisols and thermoplastic applications. The dispersant is especially suitable for inorganic pigments and filler pigments. Strong viscosities reduction so higher pigment and filler loading in the grinding process can be achieved.

Special Features

- Wetting and dispersing agent for TiO₂, inorganic pigments and fillers
- Reduce the viscosity
- increase the pigment and filler loading

Application

Low emission SMC/BMC X	■
LP and Class A formulations X	■
LS formulations X	■
Pultrusion X	■
Viscosity stabilizer	■

highly recommended ■
recommended □

Product Specification

Active ingredients	100 %
Density 20°C	1.13 g/cm ³
Acid value	106 mg KOH/g
Appearance	Slight yellowish clear liquid

Addition levels

Amount of solid additive based on pigment (SOP):

- Fillers: 0.5 - 1%
- Titanium dioxides: 1 - 2%

The above recommended levels can be used for orientation and needs to be optimized by testing

Packaging

- 25 kg
- 200 kg

Shelf life

UNIQ® SPERSE P-193 should be stored in a cool dry place. When kept in an original unopened container, it will keep up to 5 years from the date of manufacture.

UNIQ® SPERSE P-199

Wetting and dispersing additive for filled unsaturated polyesters

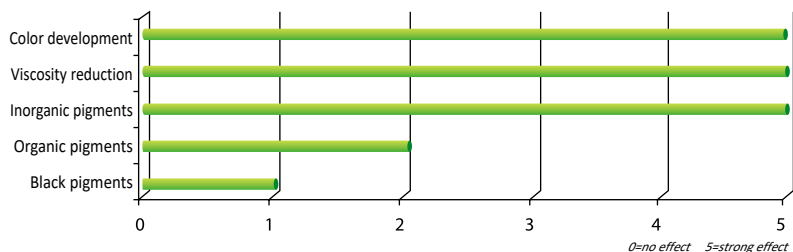

UNIQ® SPERSE P-199 is a wetting and dispersing additive for filled unsaturated polyester eg calcium carbonate and ATH. Strong viscosities reduction so higher pigment and filler loading in the grinding process can be achieved. In BMC the UNIQ® SPERSE P-199 is used as viscosity stabilizer.

UNIQ® SPERSE P-405

Liquid rheology additive enhancer

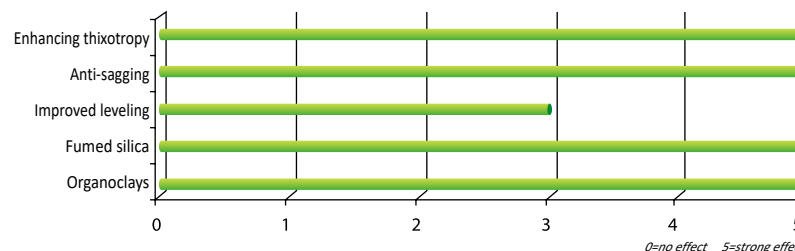

UNIQ® SPERSE P-405 is a liquid rheology additive for plastic applications such as vinyl ester and epoxy resin s, unsaturated polyester resins, and gel coats. It can reinforce the rheological effectiveness of fumed silica and organophilic phyllosilicates (organoclays). By adding P-405, incorporation of the fumed silica is made easier, separation is prevented, and the thixotropic behavior increased or stabilized.

UNIQ® SPERSE

Special Features

- Wetting and dispersing agent for TiO₂, inorganic pigments and fillers
- Reduce the viscosity
- increase the pigment and filler loading

Application

Low emission SMC/BMC X	■
LP and Class A formulations X	■
LS formulations X	■
Pultrusion X	■
Viscosity stabilizer	■

highly recommended ■
recommended □

Special Features

- reduces the viscosity of pigmented and filled PVC plastisols
- particularly recommended for inorganic pigments, zinc oxide and blowing agents
- Reduce the viscosity
- increase the pigment and filler loading
- tendency of settling is reduced

Application

Ambient curing systems	
UPE	■
Epoxy	■
PU	■
Adhesives and sealants	
UPE	■
Epoxy	■
PU	■

highly recommended ■
recommended □

Product Specification

Active ingredients	100 %
Density 20°C	0.94 g/cm ³
Acid value	84 mg KOH/g
Appearance	Slight yellowish clear liquid

Addition levels

Amount of solid additive based on pigment (SOP):

- Fillers/pigments: 0.5 - 1%
- BMC: 0.25 - 1%

The above recommended levels can be used for orientation and needs to be optimized by testing

Product Specification

Active ingredients	100 %
Density 20°C	0.95 g/cm ³
Acid value	80 mg KOH/g
Color	Max. 13
Appearance	Brownish liquid

Addition levels

Amount of solid additive based on pigment (SOP):

- Pyrogenic silica in vinyl ester resin: 20 - 50%
- Pyrogenic silica in other resin: 10 - 30%
- Organoclays 5 - 20%
- Inorganic pigments 0.5 - 2%

The above recommended levels can be used for orientation and needs to be optimized by testing

Packaging

- 25 kg
- 190 kg

Shelf life

UNIQ® SPERSE P-199 should be stored in a cool dry place. When kept in an original unopened container, it will keep up to 5 years from the date of manufacture.

Packaging

- 25 kg
- 190 kg

Shelf life

UNIQ® SPERSE P-405 should be stored in a cool dry place. When kept in an original unopened container, it will keep up to 5 years from the date of manufacture.

UNIQ® SPERSE P-904

Pyrogenic silica rheological effectiveness additive

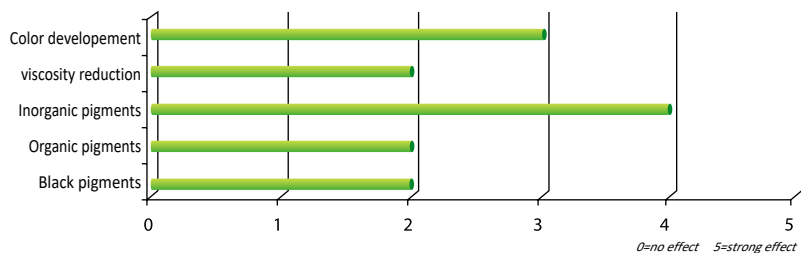

UNIQ® SPERSE P-904 is a wetting and dispersing additive in unsaturated resin systems and adhesives. It's no silicone dispersant. The additive prevents the flooding/floating and settling of pigments and fillers in epoxy and VE/UP-based laminates. Reduction in the flooding/floating of colored pigments in gel coats. And it can reinforce the rheological effectiveness of pyrogenic silica to increase and stabilize the thixotropic behavior.

UNIQ® SPERSE P-905

Pyrogenic silica rheological effectiveness additive

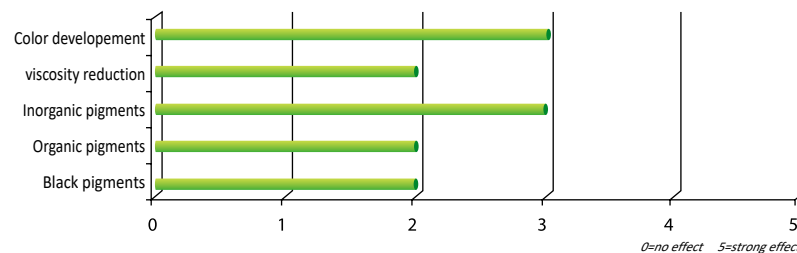

UNIQ® SPERSE P-905 is a wetting and dispersing additive in unsaturated resin systems and adhesives. It's no silicone dispersant. The additive prevents the flooding/floating and settling of pigments and fillers in epoxy and VE/UP-based laminates. Reduction in the flooding/floating of colored pigments in gel coats. And it can reinforce the rheological effectiveness of pyrogenic silica to increase and stabilize the thixotropic behavior.

UNIQ® SPERSE

Special Features

- Prevention of flooding and floating
- Reduce dispersion time
- Reduce tendency of Bernard cells
- Stabilization of the pigment dispersion
- Decrease pigment sedimentation
- Reinforce the rheological effectiveness of pyrogenic silica

Application

Ambient curing systems Vinyl / UPE Epoxy	■ ■
Adhesives and sealants Vinyl / UPE Epoxy	■ ■
Pultrusion Vinyl / UPE	■

highly recommended ■
recommended □

Special Features

- Prevention of flooding and floating
- Reduce dispersion time
- Reduce tendency of Bernard cells
- Stabilization of the pigment dispersion
- Decrease pigment sedimentation
- Reinforce the rheological effectiveness of pyrogenic silica

Application

Ambient curing systems Vinyl / UPE Epoxy	■ ■
Adhesives and sealants Vinyl / UPE Epoxy	■ ■
Pultrusion Vinyl / UPE	■

highly recommended ■
recommended □

Product Specification

Active ingredients	50 %
Solvents	Hydrocarbons C9 aromatics/Xylene/MIBK
Density 20°C	0.95 g/cm ³
Acid value	140 mg KOH/g
Color	Max.12
Appearance	Brownish liquid

Addition levels

Amount of solid additive based on pigment (SOP):

- Inorganic pigments: 1 – 2.5 %
- Titanium dioxides: 0.5 – 2 %
- Organic pigments: 1 – 3 %
- Fillers: 1 – 2 %
- Fumed silica: 5 – 40 %

The above recommended levels can be used for orientation and needs to be optimized by testing

Product Specification

Active ingredients	100 %
Density 20°C	1.04 g/cm ³
Acid value	290 mg KOH/g
Color	Max. 3
Appearance	Brownish sticky liquid

Addition levels

Amount of solid additive based on pigment (SOP):

- Inorganic pigments: 0.5 – 1.5 %
- Titanium dioxides: 0.2 – 1 %
- Organic pigments: 1 – 3 %
- Fillers: 0.5 – 1 %
- Fumed silica: 5 – 40 %

The above recommended levels can be used for orientation and needs to be optimized by testing

Packaging

- 25 kg
- 190 kg

Shelf life

UNIQ® SPERSE P-904 should be stored in a cool dry place. When kept in an original unopened container, it will keep up to 5 years from the date of manufacture.

Packaging

- 25 kg
- 190 kg

Shelf life

UNIQ® SPERSE P-905 should be stored in a cool dry place. When kept in an original unopened container, it will keep up to 5 years from the date of manufacture. At low temperature the viscosity might increase, please use after heating (50°).

Overview

Company introduction 1

Theory

Defoaming technology 4
Wetting and leveling technology 8
Dispersing technology 14
DLight Stabilization technology 22

Additives for the coating industrie

Defoamers 28-47

UNIQ®FOAM 120 S
UNIQ®FOAM 130 S
UNIQ®FOAM 131 S
UNIQ®FOAM 132 S
UNIQ®FOAM 150 S
UNIQ®FOAM 152 S
UNIQ®FOAM 170 S
UNIQ®FOAM 175 S
UNIQ®FOAM 180 W
UNIQ®FOAM LP2507
UNIQ®FOAM LP2537
UNIQ®FOAM 235 S
UNIQ®FOAM 238 S
UNIQ®FOAM 245 S
UNIQ®FOAM 272 S
UNIQ®FOAM 280 W
UNIQ®FOAM 295 W
UNIQ®FOAM LP2500
UNIQ®FOAM LP2560

Flow and leveling agents 49-69

UNIQ®FLOW 350 W
UNIQ®FLOW 361 S
UNIQ®FLOW 372 S
UNIQ®FLOW 375 S
UNIQ®FLOW 376 S
UNIQ®FLOW 380 S
UNIQ®FLOW 384 S
UNIQ®FLOW 386 S
UNIQ®FLOW 392 S
UNIQ®FLOW 400 U
UNIQ®FLOW 415 S
UNIQ®FLOW 430 S
UNIQ®FLOW 437 S
UNIQ®FLOW 440 U

UNIQ®FLOW 470 U
UNIQ®FLOW 477 U
UNIQ®FLOW 487 U
UNIQ®FLOW 488 S
UNIQ®FLOW 491 U
UNIQ®FLOW 493 U
UNIQ®FLOW 495 U

Dispersing agents 71-93

UNIQ®SPERSE 510 S
UNIQ®SPERSE 550 S
UNIQ®SPERSE 560 S
UNIQ®SPERSE 580 U
UNIQ®SPERSE 605 S
UNIQ®SPERSE 615 S
UNIQ®SPERSE 630 U
UNIQ®SPERSE 650 U
UNIQ®SPERSE 670 U
UNIQ®SPERSE 680 U
UNIQ®SPERSE 685 U
UNIQ®SPERSE 690 W
UNIQ®SPERSE 695 W
UNIQ®SPERSE 700 S
UNIQ®SPERSE 710 S
UNIQ®SPERSE 711 S
UNIQ®SPERSE 730 U
UNIQ®SPERSE 745 S
UNIQ®SPERSE 764 S
UNIQ®SPERSE 765 S
UNIQ®SPERSE 770 U

Light stabilizers and specialties 94-102

UNIQ®LIGHT 923
UNIQ®LIGHT 930
UNIQ®LIGHT 940
UNIQ®LIGHT 992
UNIQ®VIS 840 W
UNIQ®VIS 880 S

Overview

Additives for the ink industrie

Dispersing agents 106-112

UNIQ®SPERSE 9012
UNIQ®SPERSE 9315
UNIQ®SPERSE 9330
UNIQ®SPERSE 9350
UNIQ®SPERSE 9370
UNIQ®SPERSE 9450

UNIQ®JET 9506
UNIQ®JET 9510
UNIQ®JET 9515
UNIQ®JET 9520
UNIQ®JET 9525
UNIQ®JET 9530
UNIQ®JET 9053

Additives for the Plastic industrie

Defoamers 126-133

UNIQ®FOAM P-509
UNIQ®FOAM P-540
UNIQ®FOAM P-555
UNIQ®FOAM P-570
UNIQ®FOAM P-571
UNIQ®FOAM P-575
UNIQ®FOAM P-595

Flow and leveling agents 135

UNIQ®FLOW P-304

Dispersing agents 136-153

UNIQ®SPERSE P-114
UNIQ®SPERSE P-120
UNIQ®SPERSE P-130
UNIQ®SPERSE P-133
UNIQ®SPERSE P-134
UNIQ®SPERSE P-135
UNIQ®SPERSE P-136
UNIQ®SPERSE P-138
UNIQ®SPERSE P-141
UNIQ®SPERSE P-144
UNIQ®SPERSE P-145
UNIQ®SPERSE P-160
UNIQ®SPERSE P-185
UNIQ®SPERSE P-190
UNIQ®SPERSE P-191
UNIQ®SPERSE P-199
UNIQ®SPERSE P-950
UNIQ®SPERSE P-405
UNIQ®SPERSE P-904
UNIQ®SPERSE P-905

